

# Flatfire

## Wall Mount Direct Vent Gas Fireplace Model #s – FF-NG and FF-LP

# Installation & Operating Manual

*INSTALLER: Leave this manual with the appliance.*

*CONSUMER: Retain this manual for future reference.*

For the French version of this Manual, refer to the [www.wittus.com](http://www.wittus.com) web site.



**PLEASE READ THIS MANUAL BEFORE  
INSTALLING AND OPERATING THIS  
APPLIANCE.**

This appliance may be installed in an after-market permanently located, manufactured (mobile) home where not prohibited by local codes.

This appliance is only for use with the type of gas indicated on the rating plate. This appliance is not convertible for use with other gases, unless a certified kit is used.

This appliance is a domestic room-heating appliance. It must not be used for any other purposes such as drying clothes, etc.

**WARNING: If the information in these instructions is not followed exactly, a fire or explosion may result causing property damage, personal injury or loss of life.**

- Do not store or use gasoline or other flammable vapors and liquids in the vicinity of this or any other appliance.
- **WHAT TO DO IF YOU SMELL GAS**
  - Do not try to light the appliance.
  - Do not touch any electrical switch; do not use any phone in your building.
  - Immediately call your gas supplier from a neighbor's phone. Follow the gas supplier's instructions.
  - If you cannot reach your gas supplier, call the fire department.
- Installation and service must be performed by a qualified installer, service agency or the gas supplier.

**MANUFACTURED BY:**  
WITTUS INC.  
40 Westchester Ave.  
Pound Ridge NY 10576

Tested &  
Listed By  Portland  
Oregon USA  
C US  
OMNI-Test Laboratories, Inc.  
Rpt. # 297-F-01-5

# Flatfire

## Direct Vent Gas Fireplace

### TABLE OF CONTENTS

<u>Description</u>	<u>Page</u>
Important Safety & Warning Information.....	3
Specifications.....	4
Dimensions.....	4
Installation Overview.....	5
Venting.....	6
USING THE VENTING CHART.....	7
GAS VENTING CHART.....	7
VENTING CHART WORKSHEET.....	8
VENTING CHART WORKSHEET EXAMPLES.....	8
ILLUSTRATION OF VENTING ALTERNATIVES.....	9
VENT TERMINAL CLEARANCES.....	10
Unpacking and Assembly Preparation.....	11
Mounting the Flatfire.....	12
INITIAL SETUP.....	12
INSTALLATION ON AN OUTSIDE WALL.....	12
INSTALLATION ON AN INTERIOR WALL.....	13
INSTALL THE MOUNTING PLATE ON THE WALL.....	13
Final Assembly.....	14
INSTALLING OR REPLACING THE BATTERIES.....	15
PLACING THE BURNER GLASS MEDIA.....	15
RELIEF DOOR INSTALLATION.....	15
INSTALLING THE FRONT GLASS FRAME.....	16
INSTALLING THE OUTER PANELS.....	16
INSTALLING THE FIREPLACE SURROUND.....	16
Gas Connection.....	17
GAS SUPPLY LINE.....	17
GAS CONNECTION.....	17
Outer Vent Heat Shield and Termination Installation.....	18
PARALLEL INSTALLATION ON OUTSIDE WALL.....	18
OUTER VENT HEAT SHIELDS INSTALLATION).....	19
VENT PIPE AND VENT TERMINATION.....	19
Lighting and Operation.....	20
LIGHTING INSTRUCTIONS.....	20
FLAME HEIGHT ADJUSTMENT.....	21
TO TURN OFF APPLIANCE.....	21
SETTING THE TIME ON THE REMOTE.....	21
SETTING THE TEMPERATURE/TIMER.....	22
Maintenance.....	22
REPLACING THE GLASS.....	23
INSTALLING REPLACEMENT GLASS/FRAME.....	23
CLEANING THE GLASS.....	23
INSPECTING THE VENTING.....	23
CLEANING THE BURNER AND FIREBOX.....	23
AIR FLOW.....	23
Spare Parts.....	24
Warranty.....	24
Installation Record.....	25

# Flatfire

## Direct Vent Gas Fireplace

### Important Safety & Warning Information

**READ** and **UNDERSTAND** all instructions carefully before starting the installation. **FAILURE TO FOLLOW** these installation instructions may result in possible fire hazard and will void the warranty.

Prior to the first firing of the fireplace, **READ** the Owner's Information Section of this manual.

**DO NOT USE** this appliance if any part has been under water. Immediately, **CALL** a qualified service technician to inspect the unit and to replace any part of the control system and any gas control that has been under water.

#### **THIS UNIT IS NOT FOR USE WITH SOLID FUEL.**

Installation and repair should be **PERFORMED** by a qualified service person. The appliance and venting system should be **INSPECTED** before initial use and at least annually by a professional service person. More frequent cleaning may be required due to excessive lint from carpeting, bedding, etc. It is **IMPERATIVE** that the unit's control compartment, burners, and circulating air passageways **BE KEPT CLEAN** to provide for adequate combustion and ventilation air.

Always **KEEP** the appliance clear and free from combustible materials, gasoline, and other flammable vapors and liquids.

**NEVER OBSTRUCT** the flow of combustion and ventilation air. Keep the front of the appliance **CLEAR** of all obstacles and materials for servicing and proper operation. Due to the high temperature, the appliance should be **LOCATED** out of traffic areas and away from furniture and draperies. Clothing or flammable material **SHOULD NOT BE PLACED** on or near the appliance.

Children and adults should be **ALERTED** to the hazards of high surface temperature and should **STAY AWAY** to avoid burns or clothing ignition. Young children may be susceptible to accidental burns and should be **CAREFULLY SUPERVISED** when they are in the same room as the appliance. A physical barrier or safety gate is recommended if there are at risk individuals in the house.

This unit **MUST** be used with a vent system as described in this installation manual. **NO OTHER** vent system or component **MAY BE USED**. This gas fireplace and vent assembly **MUST** be vented directly to the outside and **MUST NEVER** be attached to a chimney serving a separate solid fuel burning appliance. Each gas appliance **MUST USE** a separate vent system. Common vent systems are **PROHIBITED**.

**INSPECT** the external vent cap on a regular basis to make sure that no debris is interfering with the air flow. The glass door assembly **MUST** be in place and sealed before the unit can be placed into safe operation.

**DO NOT OPERATE** this appliance with the glass door removed, cracked, or broken. Replacement of the glass door should be performed by a licensed or qualified service person. **DO NOT** strike or slam the glass door.

The glass door assembly **SHALL ONLY** be replaced as a complete unit, as supplied by the fireplace manufacturer. **NO SUBSTITUTE** material may be used.

**DO NOT USE** abrasive cleaners on the glass door assembly. **DO NOT ATTEMPT** to clean the glass door when it is hot.



**TURN OFF THE GAS BEFORE** servicing this appliance. It is recommended that a qualified service technician perform an appliance check-up at the beginning of each heating season.

Any safety screen or guard removed for servicing **MUST BE REPLACED** before operating this appliance.

**DO NOT** place furniture or any other combustible household objects within 36" of the fireplace front.

The installation must conform with local codes or, in the absence of local codes, with the *National Fuel Gas Code, ANSI Z223.1/NFPA 54*, or the *National Gas and Propane Installation Code, CSA B149.1*.

A manufactured home (USA only) or mobile home OEM installation must conform with the *Manufactured Home Construction and Safety Standard, Title 24 CFR, Part 3280* or when such a standard is not applicable, the *Standard for Manufactured Home Installations, ANSI/NCSCS A225.1*, or *Standard for Gas Equipped Recreational Vehicles and Mobile Housing, CSA Z240.4*.

The appliance and its appliance main gas valve must be disconnected from the gas supply piping system during any pressure testing of that system at test pressures in excess of ½ psi (3.5 kPa). The appliance must be isolated from the gas supply piping system by closing its equipment shutoff valve during any pressure testing of the gas supply piping system at test pressures equal to or less than ½ psi (3.5kPa).

# Flatfire

## Direct Vent Gas Fireplace

### Specifications

Description	Natural Gas	Propane
<b>INPUT</b>		
Input Rating-Btu/hr	20000	20000
Min. Input-Btu/hr	10000	10000
Orifice-DMS	#44	#55
<b>GAS SUPPLY</b>		
Min. Manifold Pressure	1.0"wc/0.3kPa	3.4"wc/0.8kPa
Max. Manifold Pressure	4.0"wc/1.0kPa	11.5"wc/2.9kPa
Min. Supply Pressure	3.5"wc/0.9kPa	8.0"wc/2.0kPa
Max. Supply Pressure	10.5"wc/2.6kPa	13.0"wc/3.2kPa
<b>EFFICIENCY</b>		
Maximum Observed Steady State Efficiency - %	78.69	79.88
Steady State Efficiency - %	62.06	65.31
Annual Fuel Utilization Efficiency (AFUE) - %	61.08	64.21
Annual Fireplace Efficiency (P.4-Canada) - %	63.46	64.42
NOTE: The maximum achievable steady state efficiency can vary depending on how the fireplace is installed and operated.		

- It is recommended that the pilot flame be turned off if the appliance will not be in use for an extended period of time.
- This appliance has been certified by OMNI-Test Laboratories, Inc. to ANSI Z21.88-2009 • CSA 2.33-2009 Vented Gas Fireplace Heaters and CAN/CGA-2.17-M91, Gas-Fired Appliances for Use At High Altitudes.
- This appliance is equipped for use with the fuel type indicated on the rating plate.
- The Flatfire is approved for installation at elevations up to 2000 feet in the U.S. and 1370 meters (4500 feet) in Canada without change. If your installation is at an elevation greater than these, consult with the local authority having jurisdiction for gas product installations to determine their specific requirements for high altitude installations.

### Dimensions

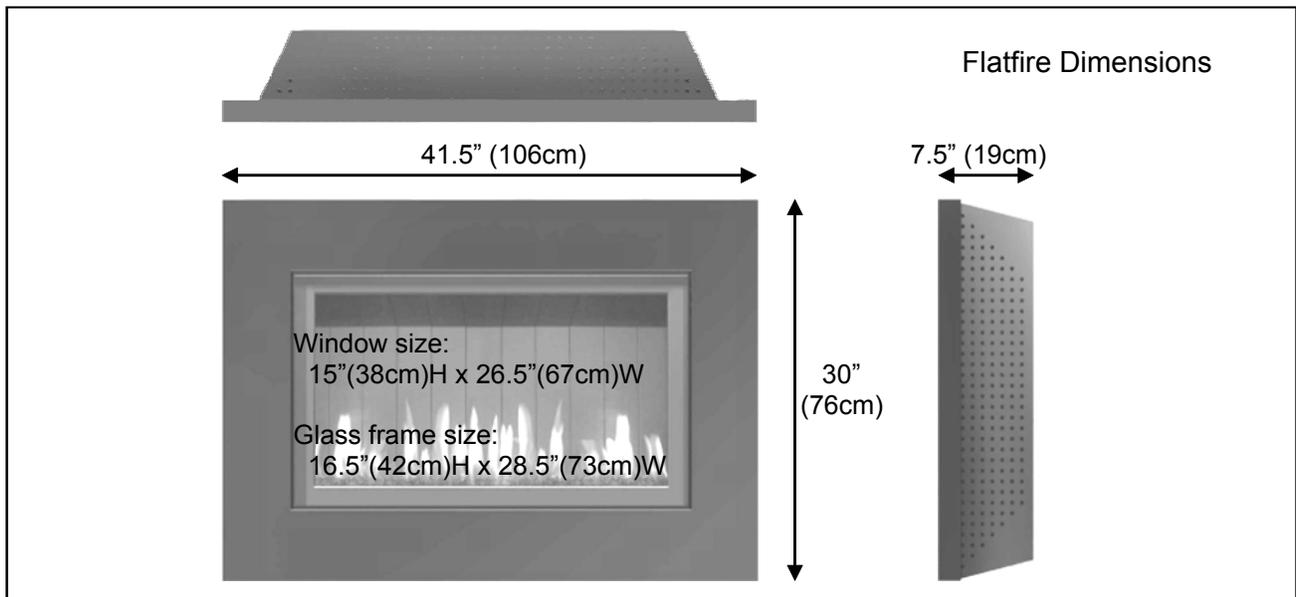

# Flatfire

## Direct Vent Gas Fireplace

### Installation Overview

Several issues must be addressed when selecting a suitable location for your Flatfire fireplace. The minimum clearances to combustible construction are listed below. In addition, access to the gas supply must be considered. The location of the fireplace will also affect the venting requirements and you must be certain the location will allow compliance with the venting requirements (on the next page). You must also insure that your installation provides adequate accessibility clearance for servicing and proper operation.

#### MINIMUM CLEARANCES TO COMBUSTIBLE CONSTRUCTION

A=Glass Frame to Left/Right Side Wall	6"(15cm)
A'=Fireplace Surround to Left/Right Side Wall	0"(0cm)
B=Glass Frame to Corner Wall	6"(15cm)
B'=Fireplace Surround to Corner Wall	0"(0cm)
C=Glass Frame to Ceiling	18"(46cm)
C'=Fireplace Surround to Ceiling	12"(30cm)
D=Glass Frame to Floor*	6"(15cm)
D'=Fireplace Surround to Floor*	0"(0cm)
E=Fireplace to Rear Wall**	0"(0cm)
Vent Pipe to Adjacent Materials	1.5"(4cm)

\* The minimum required clearance to be maintained from the fireplace to combustible flooring is measured from the top surface of carpeting, tile, etc.

\*\* Mounting plate thimbles 5/16"(8mm) thick contact the wall.

Installation and repair should be done by a qualified service person. The appliance should be inspected before use and at least annually by a professional service person. More frequent cleaning may be required due to excessive lint from carpeting, bedding material, etc. It is imperative that the control compartment, burners and circulating air passageways of the appliance be kept clean.

The gas fireplace is shipped with a plugged 3/8" NPT connection. The gas supply piping should have a separate gas shutoff valve and a 1/8" NPT plugged tapping upstream of the valve. The fireplace and its main control valve must be disconnected from the gas supply piping system during any pressure testing of that system in excess of 1/2 psi (3.5 kPa). The stove must be isolated from the gas supply piping system by closing the main control valve during any pressure testing of the gas supply system at test pressures equal to or less than 1/2 psi (3.5 kPa). After the gas supply has been connected, use a commercial gas leak detector or apply a soapy water solution to all the fittings to check for gas leaks. Never use a flame to test for leaks.

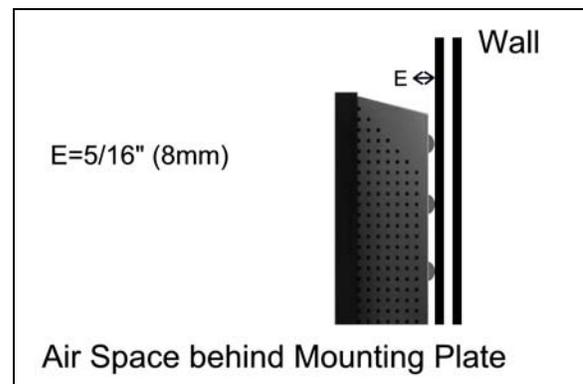
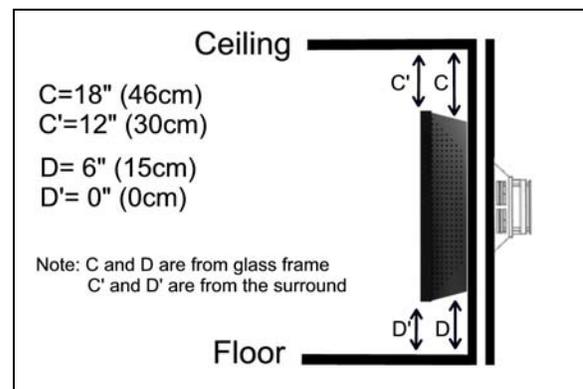
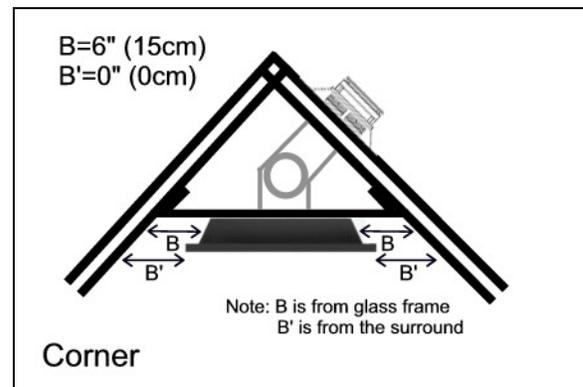
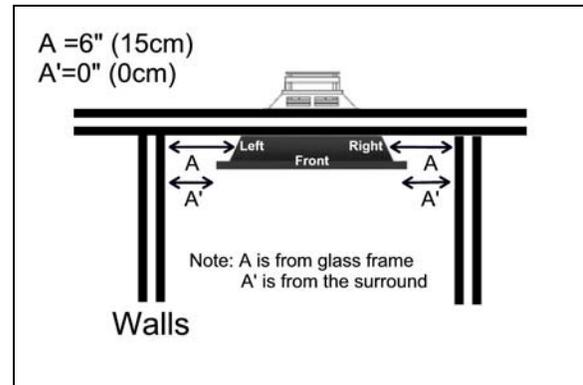

# Flatfire

## Direct Vent Gas Fireplace

### Venting

Approved Vent Terminations	Simpson DuraVent GS/Pro	Selkirk Direct-Temp	AmeriVent Direct	Metal Fab Direct Vent	ICC EXCEL Direct
Vertical Cap	46DVA-VC	4DVT-VC	4DHC	4DVA VC	
Horizontal Cap	46DVA-HC		4DVC		TM 4HT TM 4DHT
Snorkel	46DVA-SNK14				

The Flatfire Direct Vent Gas Fireplace has been tested and listed for installation with 4" X 6<sup>5</sup>/<sub>8</sub>" Simpson DuraVent GS/Pro®, Selkirk Direct-Temp®, AmeriVent Direct™, Metal Fab Direct Vent, and ICC EXCELDirect venting components.

Although you may use the pipe components (straight pipe, elbows, etc.) from any of the listed manufacturers, you may only use the vent terminations (caps) listed in the chart above. For installations where a snorkel is needed, please note that only one snorkel is approved for use. Please plan your installation accordingly.

**For all specific venting installation requirements, follow the installation instructions included by the venting manufacturer with the venting system components you have chosen.**

**Please note:**

- For venting configurations that include no vertical rise, a total horizontal vent run of up to 12 inches is allowed. However, if your installation has room to add a vertical pipe section, we suggest adding at least one foot of vertical rise to the system.
- For venting configurations that include vertical rise, it is assumed that the installation will include at least one 90° elbow. Up to three additional 90° elbows (or equivalent 45° elbows) may also be used. The number of elbows impacts the maximum allowable horizontal vent run.
- The total venting may not exceed 60 feet of vertical rise and/or 20 feet horizontal run. Custom testing is available for installations over the limits for approvals. Refer to the Venting Chart on the following page for specific details while you plan your installation.
- Many installations will involve venting directly through standard 2 x 4 or 2 x 6 construction exterior wall to a horizontal vent termination (cap). The vent starter pipe has been designed

to accommodate those installations without the use of any additional venting components other than a standard horizontal cap. See the chart above for a list of approved vent caps.

- If the Flatfire fireplace will be installed on an interior wall or other location that precludes venting directly through an outside wall to a horizontal vent cap, or if the distance to the outside wall exceeds 12", one or more elbows will be required to allow addition of the required vertical venting to the installation.

When vertical venting is required, the fireplace venting may be terminated with either a vertical or horizontal vent cap depending on the specifics of the installation. Refer to the Venting Chart on the following page for specific venting requirements and the chart above for a list of approved vent caps before you plan your installation.

- A minimum clear space of 1½" must be maintained around the vent pipe where it penetrates the first combustible wall adjacent to the fireplace (either the outside wall for the direct-through-the-wall installation or the partition wall for the 45° or other interior wall installations) and must also be maintained where the vent pipe penetrates any other interior or exterior wall, ceiling, or roof.
- The Flatfire may also be installed in front of an exiting fireplace opening. Refer to the vent manufacturers' instructions. Use the vertical venting column (0 feet horizontal run) in the venting chart to determine the requirements depending on the height of chimney.
- The location of the vent termination must meet the requirements of the current edition of ANSI Z223.1/ NFPA 54, National Fuel Gas Code or CAN B149.1, Natural Gas and Propane Installation Code and the requirements shown in the Venting Terminal Clearances section of this manual on page 5.

# Flatfire

## Direct Vent Gas Fireplace

### USING THE VENTING CHART

Just as with any other vented device, vertical vent rise creates draft (negative pressure) in the firebox as the exhaust gases heat up. If this draft becomes excessive, it can affect the performance or appearance of the fire.

**Please be sure to note that:**

1. The venting chart is for both Natural Gas and LP Gas. Determine the total vertical vent rise and total horizontal vent run for your installation. All measurements are made from the center of the vent opening in the back of the fireplace.
2. If your fireplace will not be venting directly through an outside wall to a horizontal termination or if more than 12" of horizontal vent run is required, some vertical vent rise will be required for the fireplace to function and vent

properly. Elbows will also be required for those installations. However, installations are limited to a maximum of four 90° elbows (or 45° elbow equivalents). Note: Two 45° elbows equal one 90° elbow.

3. The maximum vertical vent rise can not exceed 60 feet.
4. If your installation does not fit within the venting chart, contact Wittus - Fire by Design. Custom testing is available and may be necessary to approve the installation.
5. **The Flatfire fireplace includes a unique air inlet damper control that can be used to easily adjust the draft in the fireplace to the optimal level for installations where excessive draft might occur. The damper control can be adjusted while the fireplace is burning.**

### GAS VENTING CHART

Key:	<span style="display: inline-block; width: 15px; height: 10px; background-color: #cccccc; border: 1px solid black;"></span> = configuration allowed
	<span style="display: inline-block; width: 15px; height: 10px; background-color: #333333; border: 1px solid black;"></span> = not allowed or not tested

GAS VENTING CHART FOR BOTH NATURAL GAS AND LP (PROPANE)																						
		0	1	2	3	4	5	6	7	8	9	10	11	12	13	14	15	16	17	18	19	20
VERTICAL RISE IN FEET	60	█	█	█	█	█	█	█	█	█	█	█	█	█	█	█	█	█	█	█	█	█
	59	█	█	█	█	█	█	█	█	█	█	█	█	█	█	█	█	█	█	█	█	█
	58	█	█	█	█	█	█	█	█	█	█	█	█	█	█	█	█	█	█	█	█	█
	57	█	█	█	█	█	█	█	█	█	█	█	█	█	█	█	█	█	█	█	█	█
	56	█	█	█	█	█	█	█	█	█	█	█	█	█	█	█	█	█	█	█	█	█
	55	█	█	█	█	█	█	█	█	█	█	█	█	█	█	█	█	█	█	█	█	█
	54	█	█	█	█	█	█	█	█	█	█	█	█	█	█	█	█	█	█	█	█	█
	53	█	█	█	█	█	█	█	█	█	█	█	█	█	█	█	█	█	█	█	█	█
	52	█	█	█	█	█	█	█	█	█	█	█	█	█	█	█	█	█	█	█	█	█
	51	█	█	█	█	█	█	█	█	█	█	█	█	█	█	█	█	█	█	█	█	█
	50	█	█	█	█	█	█	█	█	█	█	█	█	█	█	█	█	█	█	█	█	█
	49	█	█	█	█	█	█	█	█	█	█	█	█	█	█	█	█	█	█	█	█	█
	48	█	█	█	█	█	█	█	█	█	█	█	█	█	█	█	█	█	█	█	█	█
	47	█	█	█	█	█	█	█	█	█	█	█	█	█	█	█	█	█	█	█	█	█
	46	█	█	█	█	█	█	█	█	█	█	█	█	█	█	█	█	█	█	█	█	█
	45	█	█	█	█	█	█	█	█	█	█	█	█	█	█	█	█	█	█	█	█	█
	44	█	█	█	█	█	█	█	█	█	█	█	█	█	█	█	█	█	█	█	█	█
	43	█	█	█	█	█	█	█	█	█	█	█	█	█	█	█	█	█	█	█	█	█
	42	█	█	█	█	█	█	█	█	█	█	█	█	█	█	█	█	█	█	█	█	█
	41	█	█	█	█	█	█	█	█	█	█	█	█	█	█	█	█	█	█	█	█	█
40	█	█	█	█	█	█	█	█	█	█	█	█	█	█	█	█	█	█	█	█	█	
30	█	█	█	█	█	█	█	█	█	█	█	█	█	█	█	█	█	█	█	█	█	
20	█	█	█	█	█	█	█	█	█	█	█	█	█	█	█	█	█	█	█	█	█	
10	█	█	█	█	█	█	█	█	█	█	█	█	█	█	█	█	█	█	█	█	█	
5	█	█	█	█	█	█	█	█	█	█	█	█	█	█	█	█	█	█	█	█	█	
1	█	█	█	█	█	█	█	█	█	█	█	█	█	█	█	█	█	█	█	█	█	
0	█	█	█	█	█	█	█	█	█	█	█	█	█	█	█	█	█	█	█	█	█	
		0	1	2	3	4	5	6	7	8	9	10	11	12	13	14	15	16	17	18	19	20
		HORIZONTAL RUN IN FEET																				

# Flatfire

## Direct Vent Gas Fireplace

### VENTING CHART WORKSHEET

#### WITTUS FLATFIRE WORKSHEET

A. FUEL TYPE:                      NATURAL GAS                       LP GAS (PROPANE)

B. TOTAL VERTICAL VENT RISE (measured from horizontal centerline of vent opening on the back of the fireplace to the horizontal centerline of the vent cap (for horizontal vent caps) or to the flange on the cap (for vertical caps)): \_\_\_\_\_ FEET

C. TOTAL HORIZONTAL VENT RUN (measured from vertical centerline of vent opening on the back of the fireplace to the flange on the cap (for horizontal caps) or to the vertical centerline of the cap (for vertical caps)): \_\_\_\_\_ FEET

**NOTE: THE VERTICAL VENT RISE AND HORIZONTAL VENT RUN ARE THE OFFSETS IN THE LOCATIONS OF VENT CAP RELATIVE TO THE VENT OPENING ON THE FIREPLACE. VENT PIPE THAT RUNS AT 45° HAS BOTH A VERTICAL RISE AND HORIZONTAL RUN. SNORKEL CAPS HAVE BUILT-IN VERTICAL RISE THAT MUST BE COUNTED.**

D. TOTAL NUMBER OF 90° ELBOWS (note – snorkels count as 2 90° elbows): \_\_\_\_\_ # 90° ELBOWS

E. TOTAL NUMBER OF 45° ELBOWS (note – 2 45° elbows count as 1 90° elbow): \_\_\_\_\_ # 45° ELBOWS

F. TOTAL 90° ELBOWS EQUIVALENT: \_\_\_\_\_ = D. + (E. x ½)

G. 90° ELBOWS IN EXCESS OF 2: \_\_\_\_\_ = F. - 2

H. ADDITIONAL HORIZONTAL FEET EQUIVALENT: \_\_\_\_\_ FEET = G. x 3

I. TOTAL HORIZONTAL VENT RUN (equivalent): \_\_\_\_\_ FEET = C. + H.

TERMINATION (CAP) TYPE:    HORIZONTAL                       VERTICAL                       SNORKEL

VENT BRAND:                      Simpson DuraVent GS/Pro®                       Selkirk Direct-Temp®   
    AmeriVent Direct™                       Metal Fab Direct Vent                       EXCELDirect

VENT CAP MODEL NO. (SEE APPROVED VENT CAPS): \_\_\_\_\_

See examples below.

### VENTING CHART WORKSHEET EXAMPLES

A. Fuel:	<b>Natural Gas</b>
B. Total Vertical Vent Rise:	<b>55 feet</b>
C. Total Horiz. Vent Run (Actual):	0 feet
D. 90° Elbows Needed:	0
E. 45° Elbows Needed:	0
F. Total 90° Elbows Equivalent :	0
G. 90° Elbows in Excess of 2:	0
H. Additional Horiz. Feet Equivalent	0
I. Total Horizontal Vent Run (Equiv.):	<b>0</b>
Vertical DuraVent 46DVA-VC Vent Cap	

A. Fuel:	<b>LP Gas</b>
B. Total Vertical Vent Rise:	<b>12 feet</b>
C. Total Horiz. Vent Run (Actual):	10 feet
D. 90° Elbows Needed:	1
E. 45° Elbows Needed:	2
F. Total 90° Elbows Equivalent :	2
G. 90° Elbows in Excess of 2:	0
H. Additional Horiz. Feet Equivalent	0
I. Total Horizontal Vent Run (Equiv.):	<b>10</b>
Horizontal DuraVent 46DVA-HC Vent Cap	

# Flatfire

## Direct Vent Gas Fireplace

### ILLUSTRATION OF VENTING ALTERNATIVES

The illustration below shows some of the many ways the Flatfire fireplace may be installed in the home. This includes interior and exterior wall installations, corner installations and horizontal and vertical vent terminations.

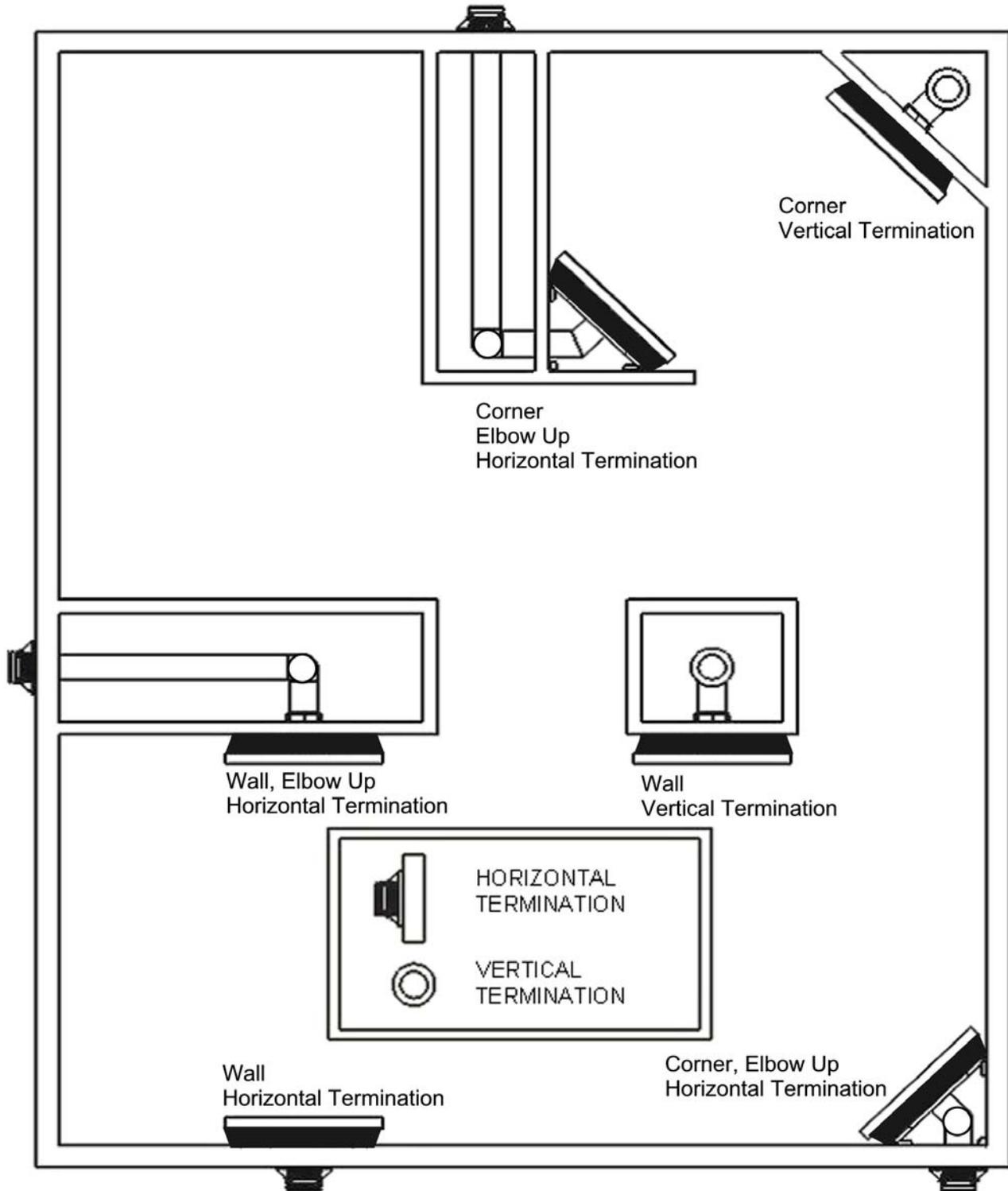

# Flatfire

## Direct Vent Gas Fireplace

### VENT TERMINAL CLEARANCES

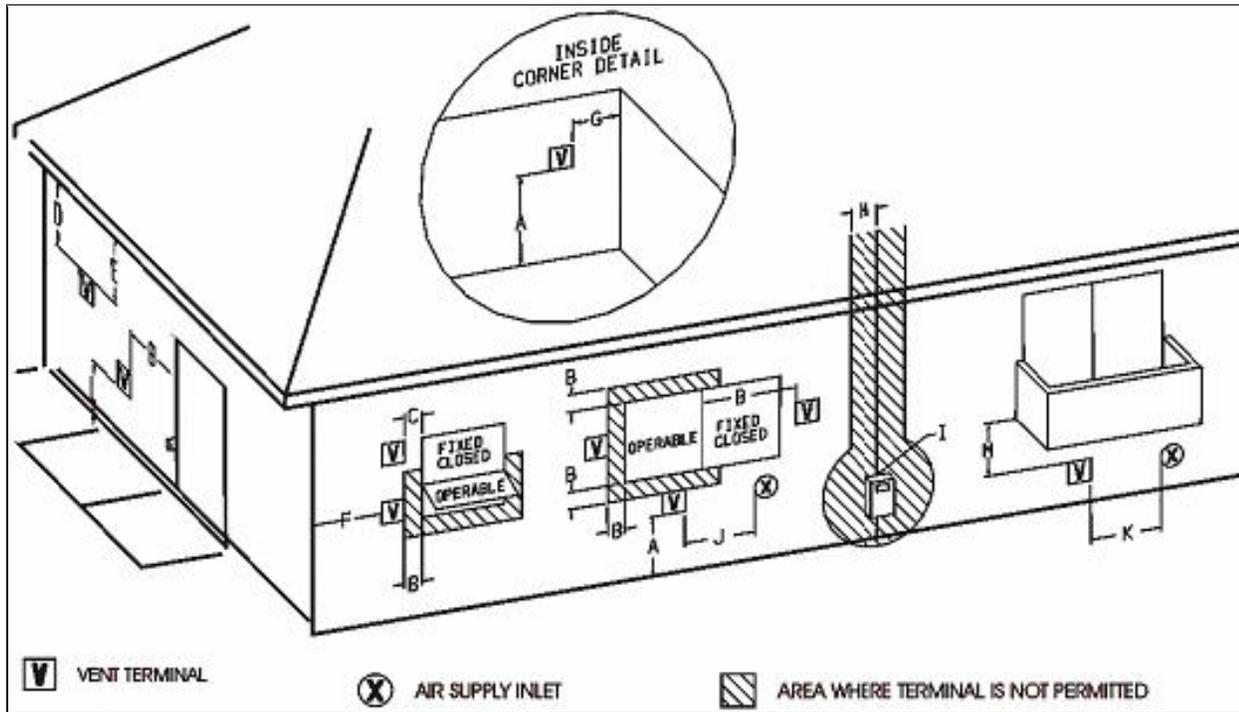

	Canadian Installations <sup>1</sup>	U.S. Installations <sup>2</sup>
A = Clearance above grade, veranda, porch, deck or balcony	12 inches (30 cm)	12 inches (30 cm)
B = Clearance to window or door that may be opened	12 inches (30 cm)	9 inches (23 cm)
C = Clearance to a permanently closed window	See Footnote 5	See Footnote 5
D = Vertical clearance to a ventilated soffit located above the terminal within a horizontal distance of 2 feet (61 cm) from the centerline of the terminal	See Footnote 5	See Footnote 5
E = Clearance to unventilated soffit	See Footnote 5	See Footnote 5
F = Clearance to outside corner	See Footnote 5	See Footnote 5
G = Clearance to inside corner	See Footnote 5	See Footnote 5
H = Clearance to each side of centerline extended above meter/regulator assembly	3 feet (91 cm) within a height of 15 feet (4.5 m) above the regulator/meter assembly	See Footnote 5
I = Clearance to service regulator vent outlet	3 feet (91 cm)	See Footnote 5
J = Clearance to non-mechanical air supply inlet to building or the combustion air inlet to any other appliance	12 inches (30 cm)	9 inches (23 cm)
K = Clearance to a mechanical air supply inlet	6 feet (1.83 m)	3 feet (91 cm) above if within 10 feet (3 m) horizontally
L = Clearance above paved sidewalk or paved driveway located on public property	7 feet (2.12 m)	See Footnote 5
M = Clearance under veranda, porch, deck or balcony	12 inches (30 cm) See Footnote 4	See Footnote 5

**Footnotes**

- 1 In accordance with the current CSA B149.1, Natural Gas and Propane Installation Code
- 2 In accordance with the current ANSI Z223.1 / NFPA 54, National Fuel Gas Code
- 3 A vent shall not terminate directly above a sidewalk or paved driveway that is located between two single family dwellings and serves both dwellings.
- 4 Permitted only if veranda, porch, deck or balcony is fully open on a minimum of two sides below the floor.
- 5 Clearance in accordance with local installation codes and the requirements of the gas supplier.

**Venting terminals should not be recessed into a wall or siding.**

# Flatfire

## Direct Vent Gas Fireplace

### Unpacking and Assembly Preparation

The fireplace components are shipped in three cartons. The first and largest carton contains:

- this Flatfire manual,
- fireplace mounting template,
- bag of glass burner media,
- remote control handset,
- hardware bag,
- two relief doors with gaskets,
- four outer decorative panels,
- firebox with caution label attached, and
- mounting plate.

The second carton contains the fireplace surround.

The third carton contains the vent starter pipe and vent pipe shields.

To unpack the Flatfire, follow these steps:

1. First lift and remove the section from the carton containing the firebox. Carefully unpack the contents and set aside. This should include the manual, the wall mounting template, the bag of glass burner media, the remote control handset, a hardware bag and the two relief doors with gaskets.
2. Next lift off the glass protector board and remove the other sections from the carton. Carefully remove the contents. This includes the four decorative panels that will be attached to the fireplace during assembly. Note that the right panel has a touch pad control panel and cable attached. Use special care when unpacking and handling the right panel to avoid damaging the cable or pad.
3. Next, remove all remaining packing material from the carton.
4. Lift the firebox out of the carton. **Note the caution label is attached to the firebox.** The best place to lift is at its sides. Finally, remove the fireplace mounting plate up and out of the carton. This should be all the parts from the first carton.
5. Next, unpack the fireplace surround from the second carton and set aside on a soft surface for later use.
6. Finally, unpack the vent starter pipe (with attached gasket) and the vent pipe shields from the third carton and set aside for later use.

Before you begin the fireplace mounting process there are several installation requirements that must be met. Careful planning will make the installation easier to accomplish and will reduce the chances of encountering problems after you start.

1. The fireplace is designed to be wall-mounted using four lag bolts to secure the fireplace mounting plate to the wall structure. The mounts are located 16" on center and 24" on center to correspond with standard building construction. If your home has non-standard construction or the location you have chosen for the fireplace does not have wall studs that correspond to location of the fireplace mounts, modifications to the wall structure will be needed. **It is critical that the four lag bolts that are provided for mounting the fireplace are firmly imbedded into the wall structure at all four locations.**
2. A hole must be provided in the wall for the vent to pass through. The hole must be large enough to provide 1½" clearance around the outside of the vent pipe and to allow for installation of the vent heat shields that are provided with the fireplace. Follow the hole size requirements that are provided below exactly to avoid problems. If the location you have chosen does not allow for 1½" clearance to wooden framing in the wall, modifications to the wall structure must be made to obtain the needed vent pipe clearance.
3. All required minimum clearances to adjacent combustible materials (including side walls, ceiling and floor) must be achieved with the position you have chosen. Refer to the Clearance Information in the Installation Overview section (page 5). The listed clearances are measured from the both the outermost front edges of the fireplace surround and from the edge of the glass frame. In addition the requirements for clearance to combustible materials inside the house, there are specific requirements and limitations that must be met for the location of the vent terminal relative to doors, windows, corners, eaves, gas supply components and other structural elements of the house. Refer to the specific requirements in the Vent Terminal Clearances (page 10). Again, plan the installation in advance to avoid problems.
4. The gas supply line must be located within a specific area behind the fireplace.

# Flatfire

## Direct Vent Gas Fireplace

### Mounting the Flatfire

#### INITIAL SETUP

Once you are certain that the location you have chosen meets all the necessary mounting and safety requirements, you can begin the installation.

1. Tape or pin the installation template to the wall in the position where the fireplace is to be mounted. Note: It is important that the fireplace is mounted in a level position. Use a spirit level placed on the cross-hairs in the upper mounting holes on the template, and adjust the template position until the mounting holes are level. Refer to the illustration below.
2. Next, carefully transfer the location of the two upper and two lower mounting holes that you will use for your installation. Use a sharp nail, awl or pin to pierce the template on the mounting hole cross-hairs to insure an accurate transfer to your wall.
3. Next transfer the location for the center of the vent pass-through hole on the wall. Also transfer at least one point on the diameter of the vent pass-through circle. This will make it easier to scribe the circle later.
4. Finally, transfer the location of the gas supply line.
5. Remove the template and circle the transferred locations with a pencil or marker.

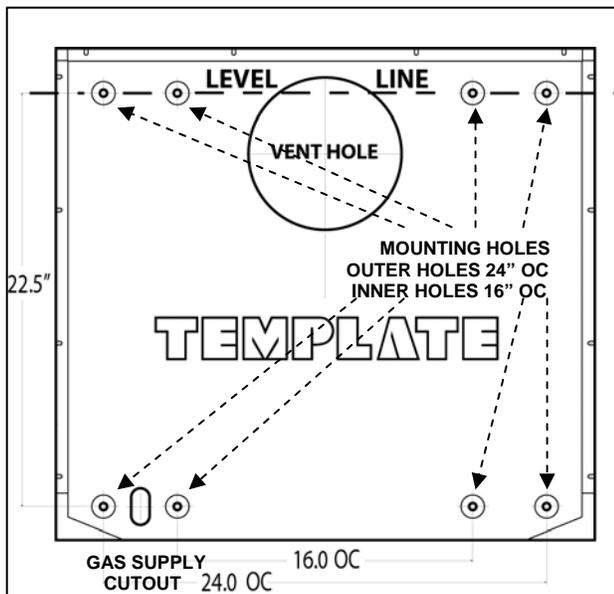

#### INSTALLATION ON AN OUTSIDE WALL

Assembly steps for Vent Pass-Through (Parallel Wall Installation on an Outside Wall):

1. An unobstructed wall pass-through is required to allow for a safe installation of the fireplace vent components. This will necessitate removal of a portion of the interior wall covering (e.g., sheetrock or plaster and lath), outer wall sheathing and outer wall covering and any adjacent internal wall materials (like insulation).
2. Scribe a 9 $\frac{5}{8}$ " diameter hole around the vent pass-through center mark using a compass.
3. Use a long drill ( $\frac{1}{8}$ " diameter) that is held square and level to the inside wall to transfer the vent pass-through center location from the inner wall covering through to the outer wall sheathing and outer wall covering.
4. Carefully cut the inner wall covering along the scribed line and remove the circular wall piece.

Note: It is important to locate electrical wiring in the wall before beginning the installation process. An electrician should be consulted if there is any question about wiring locations. Failure to locate and protect wiring during the installation process may result in electrical shock or fire.

5. Remove any insulation materials from wall in the area defined by the pass-through hole.
6. Building codes in your area may require that you add blocking above and below the vent opening. The blocking should be above and below the 9 $\frac{5}{8}$ " vent opening you made in the wall and should not obstruct that opening. The blocking should extend to adjacent wall studs.
7. Next, mark and cut a 9 $\frac{5}{8}$ " diameter hole through the outer wall covering and sheathing using the locating hole you drilled in Step 2.
8. Follow the instructions included with the vent termination (cap) to remove the appropriate amount of outer wall covering (siding) or to install the vinyl siding shield if used.

Do not install the chimney cap at this point.

# Flatfire

## Direct Vent Gas Fireplace

### INSTALLATION ON AN INTERIOR WALL

Assembly steps for Vent Pass-Through (Parallel Wall Installation on an Interior Partition Wall):

1. An unobstructed wall pass-through is required to allow for a safe installation of the fireplace vent components. This will necessitate removal of a portion of the interior wall covering (e.g. sheetrock or plaster and lath), on both sides of the partition wall and any adjacent internal wall materials (like insulation).
2. Scribe a 9 $\frac{5}{8}$ " diameter hole around the vent pass-through center mark using a compass.
3. Use a long drill ( $\frac{1}{8}$ " diameter) that is held square and level to the inside wall to transfer the vent pass-through center location from the inner wall covering through to the wall covering on the back side of the partition wall.
4. Carefully cut the inner wall covering along the scribed line and remove the circular wall piece. Note: It is important to locate electrical wiring in the wall before beginning the installation process. An electrician should be consulted if there are any questions. Failure to locate and protect wiring during the installation process may result in electrical shock or fire.
5. Remove any insulation materials from wall in the area defined by the pass-through hole.
6. Building codes in your area may require that you add blocking above and below the vent opening. The blocking should be above and below the 9 $\frac{5}{8}$ " vent opening you made in the wall and should not obstruct that opening. The blocking should extend to adjacent wall studs.
7. Next, mark and cut a 9 $\frac{5}{8}$ " diameter hole through the wall covering on the back side of the partition wall using the locating hole you drilled in Step 2.
8. When installing the fireplace on a partition wall, the venting may penetrate one or more interior walls, an exterior wall, the ceiling or the roof.
9. It is important to lay out the locations of all vent pass-through's before you begin the installation to insure that the venting will line-up correctly and that the walls and ceiling meet the needed clearances to the vent pipe.
10. The vent pass-through in the partition wall where the fireplace is mounted must be done in accordance with the instructions for a parallel wall installation on an outside wall, following steps 1 through 6.

### INSTALL THE MOUNTING PLATE ON THE WALL

Installation steps of the Mounting Plate on the wall:

1. The fireplace mounting plate is attached to the wall structure using four  $\frac{1}{4}$ " X  $1\frac{1}{2}$ " long lag bolts and large diameter washers that are provided with the fireplace. It is important to use the included hardware as the full weight of the fireplace is supported by the mounting plate.
2. Drill a  $\frac{5}{32}$ " diameter pilot hole at each of the mounting hole locations marked using the template. The pilot holes should be the full depth of the lag bolts. Be sure that there is solid wood at each mounting location. If not, reconstruct to provide the needed support.
3. Before the mounting plate can be lagged to the wall the two sections of the telescoping vent pipe heat shields that you set aside earlier must be attached to the mounting plate. The inner heat shield half with the tabs (smaller diameter of 7.9") is held in place with three sheet metal screws (provided) and is installed from the front of the back mounting plate. Slide the inner heat shield half through the vent pipe opening in the mounting plate. Align the three tabs with the pilot holes in the mounting plate (as shown in the illustration below) and install the 3 screws.

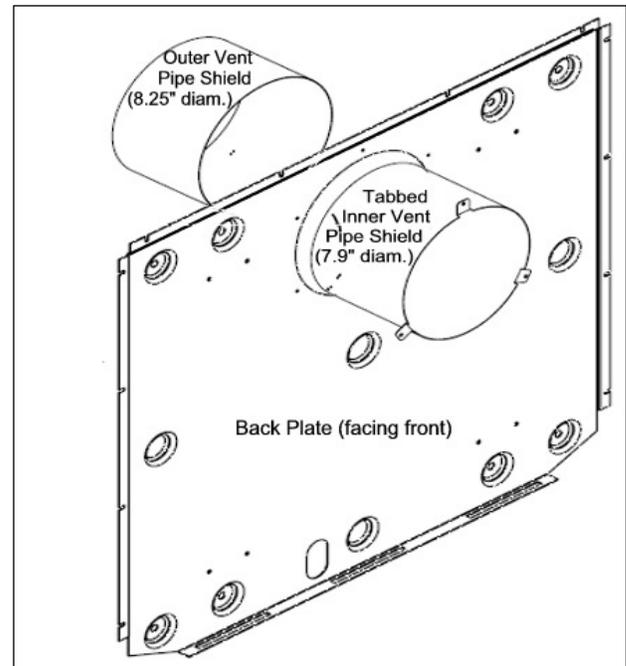

4. The outer vent pipe heat shield half (larger diameter of 8.25) is installed on the rear of the mounting plate. Slip the outer shield half over the inner shield and align and install the three screws. See illustration above.

# Flatfire

## Direct Vent Gas Fireplace

5. The fireplace mounting plate is now ready to be lagged to the wall structure. With a helper pick up and align the mounting plate over the gas supply line and line up with the four mounting lag bolt pilot holes. These holes are in recessed bosses. Use either the 16" or 24" on center holes depending on the construction of the wall.
6. Using the lag bolts and washers provided with the fireplace, install the top lag bolts (with washers) first, followed by the lower ones. Use a 7/16" socket wrench to tighten the lag bolts.  
**Note: It may be helpful to put a light coating of dish or hand soap on the lag bolts to reduce resistance when tightening.**
7. At this point, check to be sure that there is a 5/16" air gap between the entire flat back surface of the mounting plate and the wall surface. The gap is critical to a safe installation, so if the gap is obstructed in any way, remove the obstruction before proceeding.
8. Next check that the brackets on the mounting plate that actually hold the fireplace are level, again using a spirit level.
9. If the brackets are not perfectly level, you can adjust the right bracket by loosening the bracket fasteners and moving the bracket until it is level with the left bracket. Remember to tighten the bracket fasteners once you have achieved a level position.
10. The next step is to install the vent starter pipe onto the fireplace.
11. First, you should remove the glass frame from the front of the firebox by unclipping the clips on the side. While holding the frame, gently lift it up and out of the groove on the bottom. Set the glass frame aside in a safe flat place.
12. Carefully place the fireplace with the front down on a protected floor.
13. Place the vent starter pipe gasket on the back of the fireplace aligning the holes in the gasket with the pilot holes on the rear of the fireplace.
14. Align the inner pipe of the vent starter pipe with the exhaust outlet pipe on the fireplace. The vent pipe will fit tightly over the fireplace pipe.
15. Gently push the starter pipe on to the fireplace pipe until the outer pipe flange makes contact with the starter pipe gasket. Be sure that the holes in the starter pipe flange align with the gasket and pilot holes. When the flange contacts the gasket, install the four fasteners provided with the starter pipe.

## Final Assembly

Now you are ready to install the fireplace on the mounting plate. This will require a helper as the fireplace is quite heavy.

1. Lift the fireplace up and guide the vent pipe into the vent pipe opening in the mounting plate. The vent pipe must be at the highest location possible in the vent pipe opening (almost touching the inner vent pipe heat shield) to allow the mounting tabs on the rear of the fireplace to clear the top of the mounting brackets on the mounting plate.
2. While looking in from the sides, guide the upper and lower mounting tabs on the back of the fireplace into the corresponding brackets on the mounting plate. When the tabs and brackets are aligned, push the fireplace down and in to engage the tabs in the brackets. Note: The weight of the fireplace is carried only on the top brackets. The bottom brackets function simply to keep the bottom of the fireplace from moving. Refer to the illustration below.

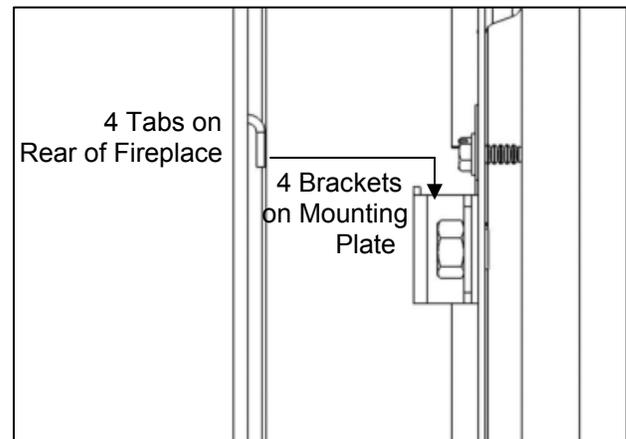

3. If the fireplace is properly positioned on the brackets the vent starter pipe and vent heat shields should be concentric when viewed through the vent pass-through in the wall. Go outside and look in the hole to confirm this. If you are mounting the fireplace on a 45° partition wall, look in the pass-through using a mirror if needed.
4. If the vent starter pipe and vent pipe heat shields do not appear to be concentric, check to be sure that the mounting tabs on the fireplace are all fully engaged in the brackets on the mounting plate and that the upper two tabs are sitting down on the upper brackets. If they are not, adjust the fireplace until they are.

# Flatfire

## Direct Vent Gas Fireplace

### INSTALLING OR REPLACING THE BATTERIES

1. The valve control module is powered by four (4) AA batteries. The battery pack is located on the bottom left of the fireplace and held in a mounting bracket. **Batteries should last one to two seasons, depending on usage. Replacement is recommended at the beginning of the heating season. Three short beeps is an indication of a low battery.**
2. Pull the battery pack out of the mounting bracket. The batteries are located on the top - slide and remove the receiver cover. **Do not use metal tools to remove batteries.** Install 4 high quality alkaline AA batteries\* using the guides inside the battery pack to show you the correct battery orientation. Replace the cover and put the battery pack on the bracket.
3. The remote handset is powered by one 9V battery. The access panel is located on the back of the handset and simply snaps open to provide access to the battery compartment. Connect a high quality alkaline 9V battery\* to the battery connector. Replace the remote handset access panel. **“BATT” will appear on the display as a low battery indication.**

\*Note: To insure that only fresh batteries are used, batteries are not supplied with the fireplace. These will be supplied by the installer.

### PLACING THE BURNER GLASS MEDIA

The burner glass media poly-bag that was set aside contains the proper amount of glass material to cover the burner. Empty the entire contents of the bag and distribute evenly over the burner tray.

1. Locate the burner in the fireplace. Clip a corner of the poly-bag to form a pouring spout. The opening should be large enough to allow the glass media to flow so it is controlled.
2. Note the burner surface is designed with turned-up edges that form a tray to hold the glass media. Starting at one end, pour the glass media onto the burner tray, keeping the spout toward the center of the burner to avoid spillage of glass pieces over the sides of the burner.
3. Once the glass burner media is poured, smooth the glass pieces out so they have a uniform depth over the entire surface of the burner. If a few pieces of glass spill during installation, it is not a problem. See the illustration below.



### RELIEF DOOR INSTALLATION

1. The two relief doors are shipped separately from the fireplace and must be installed on the top of the firebox at this point in the installation. Note: The relief doors include a gasket material that covers the full bottom surface. Use care in handling the relief doors to avoid damage to the gasket material. The illustration below shows one of the two sets of relief openings and relief door retainers.

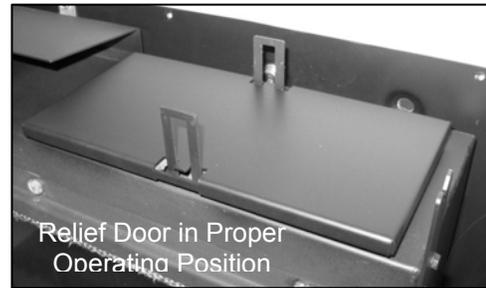

2. The relief doors include line-up tabs that correspond to slotted retainers on the firebox. Tip each relief door enough to allow the rear line-up tab to engage the rear retainer slot. Refer to the illustration below.

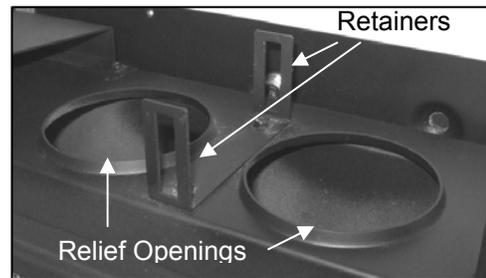

3. Rotate the front edge of each relief door so they line-up over front retainers. Gently spring the front forward so it will allow the relief door front line-up tab to engage on the retainer.

The relief doors should be able to move up and down freely on the retainers if properly installed. When the relief door installation is complete, the doors should be in the full down position. Refer to the illustration below.



# Flatfire

## Direct Vent Gas Fireplace

### INSTALLING THE FRONT GLASS FRAME

After burner media and relief doors have been installed, the next step is to replace the front glass frame.

1. Carefully pick up the glass frame by grasping the sides of the frame.
2. With the glass frame held at a slight angle (leaving room for your fingers between the frame and the firebox) insert the bottom edge of the frame into the frame groove located on the bottom front of the firebox. Take care to center the frame from left to right.
3. Once the bottom edge is in place, press the frame against the firebox and clip in the sides. Make sure the frame is locked into place correctly with the latches on each side.

### INSTALLING THE OUTER PANELS

1. The four outer decorative panels are secured to the fireplace with Philips-head screws. The top and bottom panels are secured to the fireplace mounting plate with sheet metal screws. All other screws are Philips-head machine screws.
2. Install the top panel first. Align the four holes along the rear edge of the panel with pilot holes along the top edge of the fireplace mounting plate. Insert and tighten the four sheet metal screws. A magnetic nut driver is helpful.
3. Install the left side panel next. Align the three holes along the rear edge of the panel with the PEM nuts along the edge of the fireplace mounting plate. Insert the three Philips-head screws but do not fully tighten. Locate the fastener hole at the top front edge of the left side panel and align with the PEM nut in the front of the top panel. Insert the Philips-head screw. Make sure the edges of the panel are aligned with the edges of the top panel and mounting plate and tighten all four screws.
4. The right side panel has the manual control touch pad mounted near the back edge. Before this panel can be installed, the touch pad must be connected to the battery pack on the lower left of the firebox. Connect the cable and then install the right side panel following the same step (3.) above as the left side.
5. Attach the bottom panel to the side panels by aligning the fastener holes in the bottom panel with the PEM nuts in the front corners of the bottom flanges on the side panels. Insert and tighten the two Philips head screws.

### INSTALLING THE FIREPLACE SURROUND

The decorative surround for the Flatfire fireplace is held in place by two slots (cutouts) located in the upper area of the inner frame of the surround and two self-locking tabs at the bottom of the inner frame.

1. Unpack the surround from shipping box.
2. With a helper, lift the surround up and identify the top by looking for the two slots near the top of the inner frame.
3. Line up the slots on the surround with the shoulder bolts on the firebox frame, centering the surround opening over the glass panel. Gently push into place slowly while applying gentle pressure until the sides lock into place.
4. Carefully swing the bottom of the surround toward the base of the fireplace and apply gentle pressure until the self-locking tabs on each side are engaged.
5. To remove the surround, gently pull the bottom edge of the surround outward to disengage the tabs and then lift the top up and off the upper shoulder bolts.
6. To prevent damage to the surround, always set the surround in a safe place while it is removed from the fireplace.

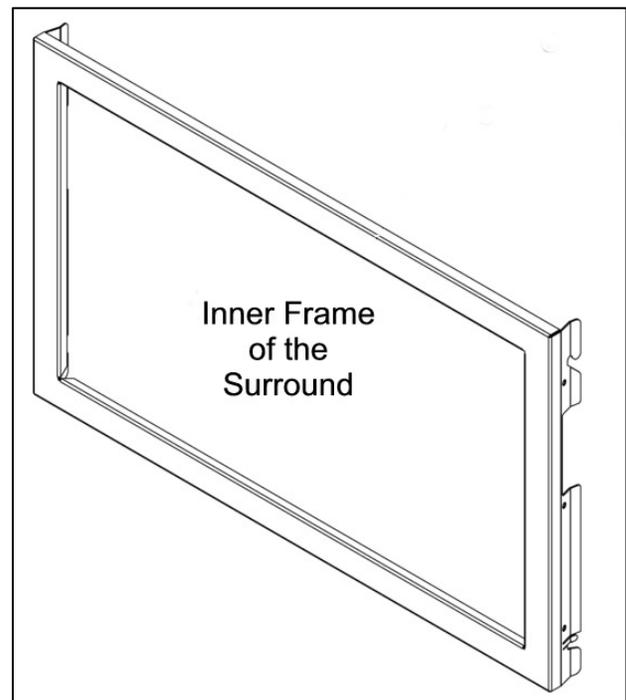

# Flatfire

## Direct Vent Gas Fireplace

### Gas Connection

#### GAS SUPPLY LINE

Once the vent pass-through (or pass-through's) are finished, the gas supply line should be installed.

The supply line should exit the wall that the fireplace will be installed on at the location specified on the installation template (see illustration of the template on page 12).

In every case, the installation must conform with local codes or, in the absence of local codes, with the *National Fuel Gas Code, ANSI Z223.1* or the *Canadian Installation Code, CAN/CGA B149*.

We suggest the installation of a shut-off valve in the supply line between the wall and the connection to the fireplace. Your professional gas installer or local gas company will determine the specific requirements for the gas supply line as the requirements may vary in different locations.

Specifically, we recommend installing a shut-off valve between the gas supply line where it penetrates the wall / fireplace mounting plate and the inlet to the control valve on the fireplace. This will allow gas to be shut-off to the fireplace by simply removing the fireplace surround to gain access to the shut-off valve.

The illustration below shows the Gas Supply Line connection to Control Valve Inlet - ●●, and the recommended location for Shut-off Valve - ◀.

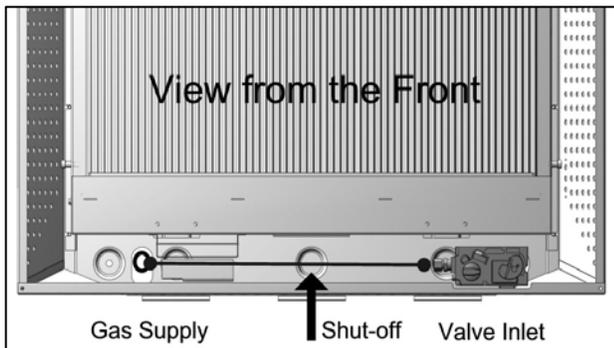

#### GAS CONNECTION

1. Verify that the gas type is correct for the fireplace by looking at the rating plate that is attached to the right side of the fireplace.

Note: The fireplace is shipped from the factory equipped to burn the fuel listed on the rating plate. Fuel conversion in the field is not allowed.

2. The gas connection should now be made from the gas supply line to the control valve inlet on the fireplace. Use only a qualified gas installer to make the connection.
3. The fireplace is shipped from the factory with a plugged  $\frac{3}{8}$ " NPT connection.
4. The gas supply piping should have a separate gas shut-off valve and a  $\frac{1}{8}$ " NPT plugged tapping upstream of the valve.

Refer to the illustration at the lower left on this page for the recommended installation location for the shut-off valve. This will enable the gas to be shut-off to the fireplace by simply removing the fireplace surround to gain access to the shut-off valve.

5. The fireplace and its main burner valve must be disconnected from the gas supply piping system during any pressure testing of that system at test pressures in excess of  $\frac{1}{2}$  psi (3.5kPa).
6. The fireplace must be isolated from the gas supply piping system by closing the gas shut-off valve during any pressure testing of the gas supply system at test pressures equal to or less than  $\frac{1}{2}$  psi (3.5kPa).

After the gas supply has been connected, use a commercial gas leak detector or apply a soapy water solution to all the fittings to check for gas leaks.

**Never use a flame to test for leaks.**

# Flatfire

## Direct Vent Gas Fireplace

### Outer Vent Heat Shield and Termination Installation

#### PARALLEL INSTALLATION ON OUTSIDE WALL

Steps to install the Outer Vent Heat Shields and Vent Termination (Parallel Installation):

1. Before you install the horizontal vent termination, you must first install the second halves of the two telescoping vent pipe heat shields. Each shield half simply slips over the half you previously attached to the fireplace mounting plate and can now be seen inside the vent pass-through in the wall.
2. Install the outer shield first and the inner second. Leave about 1¼" of the shields protruding past the house sheathing.
3. Install the horizontal vent termination (vent cap) by first removing the two mounting straps as they will not be used. Be sure the arrow on the cap (if present) is pointing up and reconfirm that all the vent cap location requirements and the vent manufacturer's requirements are met.
4. Slip the inner and outer vent termination pipes onto the vent starter pipe taking care to align the inner and outer pipes to prevent damage.
5. Slide the vent termination (cap) into the siding recess (or vinyl siding shield) until it bottoms out.

Note: The rear surface of the vent termination will push the telescoping vent pipe heat shields inward. When the vent termination is in place the heat shields will just touch the rear surface of the termination.

6. Pull the vent cap away from the sheathing and install a small bead of non-hardening silicone sealer around the cap perimeter. Push the cap in place.
7. Install the mounting screws (included with the cap) to hold the vent cap to the sheathing. See the venting manufacturer's instructions for the location of the mounting holes.

Typical mounting hole locations are shown in the illustration at right. Refer to the venting manufacturer's instructions for more information or if using the vinyl siding shield.

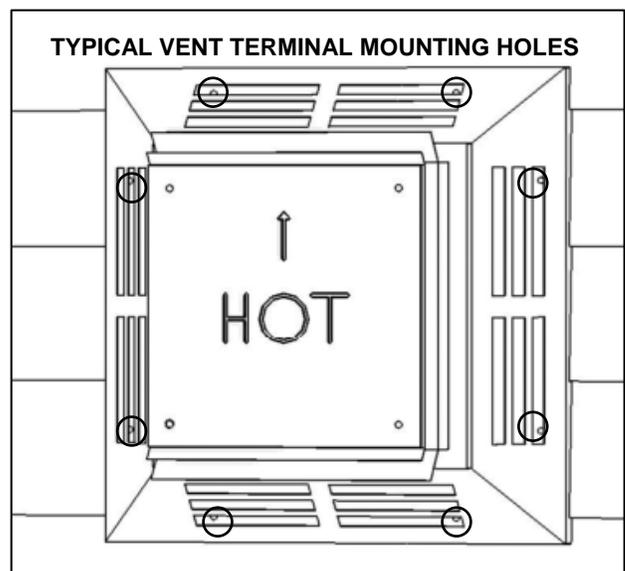
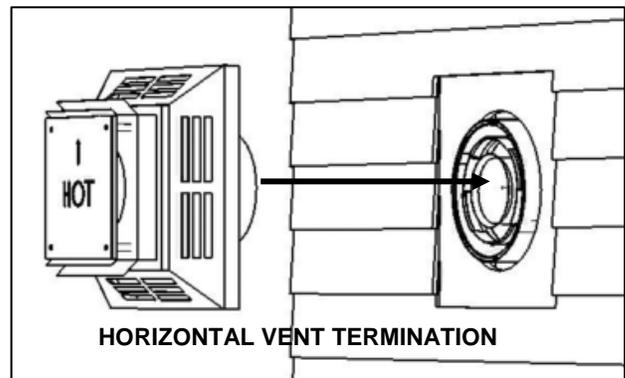
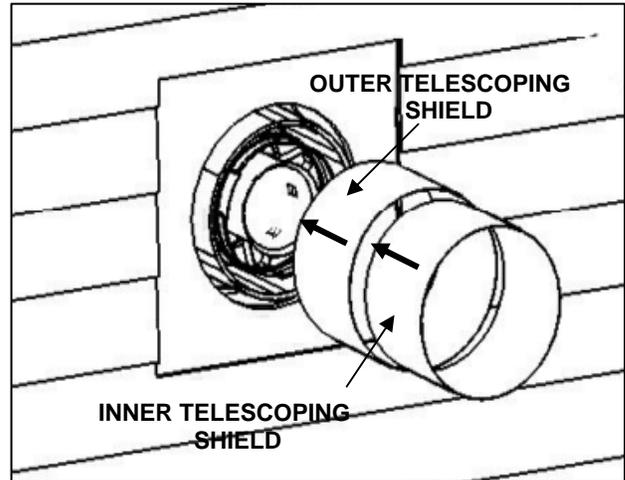

# Flatfire

## Direct Vent Gas Fireplace

### OUTER VENT HEAT SHIELDS INSTALLATION)

Steps to install the Outer Vent Heat Shields (Partition Wall Installation):

1. Before you install the additional vent pipe and elbow(s) that will complete the venting installation, you must first install the second sections of the vent pipe heat shields to protect the combustible materials around the vent pipe pass-through in the partition wall that the fireplace is mounted on.

Each shield half simply slips over the half you previously attached to the fireplace mounting plate and that can now be seen inside the vent pass-through in the partition wall.

2. Install the outer shield first and the inner second. Leave at least 2" of both shields protruding past the partition wall framing or wall covering. See the illustration below.

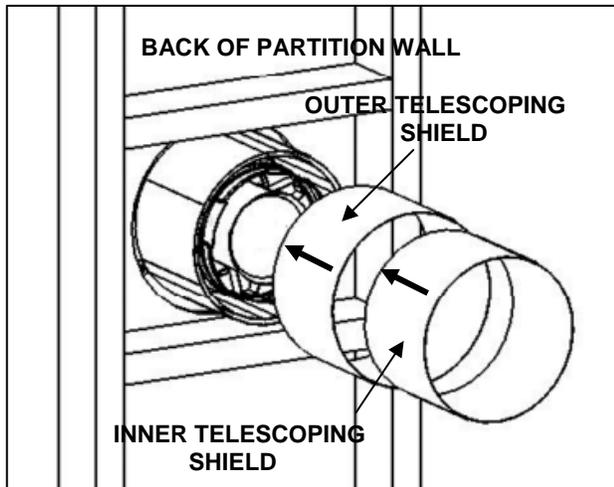

### VENT PIPE AND VENT TERMINATION

Steps for Vent Pipe and Vent Termination Installation (Partition Wall Installation):

1. The specific details of the vent configuration from the vent starter pipe on the fireplace to the horizontal or vertical vent termination (cap) when the fireplace is installed on an interior wall of the house will vary depending on the location of the fireplace on the wall, what is on the back side of the wall, where the vent termination will be located (roof or exterior wall) and on other code requirements for the location of the vent termination. However, the maximum vent length, measured along the centerline of the pipe, from the back of the fireplace to the start of the vent termination cannot exceed 30 feet, including a maximum of 20 feet of vertical rise and a maximum of 10 feet of horizontal run. If more than two 90° elbows (or equivalent 45° elbows) are needed for your installation, the maximum amount of horizontal run allowed is reduced. See the Venting Chart on page 7 for specific information. It is important to plan the installation in advance so that you can accurately locate the any wall or ceiling pass-through's and the vent termination on the exterior wall or roof. The vent pipe sections are available only in certain increments of length and in adjustable length sections. Plan carefully before you start!
2. You will find it helpful to leave access to the area behind the partition wall to facilitate installation of the vent components. The pipe sections may have twist lock connections which will be difficult to execute without good access.
3. Be sure that the two vent pipe heat shields extend at least 2" beyond the rear side of the partition wall adjacent to the fireplace after the venting is installed.
4. Maintain a minimum 1½" unobstructed air space around the vent pipe where it passes through other interior walls, the ceiling, the exterior wall or the roof.

**Note: Vent manufacturer's instructions and some building codes may require the addition of blocking above and below all wall pass-through's, the addition of vent manufacturer supplied fire-stops, wall thimbles, attic insulation shields, interior trim collars, vent support brackets, or other components. Please check with the authority having jurisdiction in your area when planning the venting installation to determine the specific code requirements and exact venting components that are required for your installation.**

# Flatfire

## Direct Vent Gas Fireplace

### Lighting and Operation

#### FOR YOUR SAFETY – READ BEFORE OPERATING

**WARNING** - Fire or explosion hazard. Attempted disassembly or repair of controls can cause property damage, severe injury or death. Do not disassemble the gas valve; it contains no serviceable components. If you do not follow the information in this manual exactly, a fire or explosion may result causing property damage, personal injury or loss of life.

- A. This appliance is equipped with an ignition device which automatically lights the pilot. Do not try to light the pilot by hand.
- B. **BEFORE OPERATING** verify that no gas is in the area around the appliance, including near the floor.
 

**WHAT TO DO IF YOU SMELL GAS:**

  - a. Do not try to light any appliance.
  - b. Do not touch any electrical switch; do not use any phone in your building.
  - c. Immediately call the gas supplier from a neighbor's phone. Follow the gas supplier's instructions.
  - d. If you cannot reach the gas supplier, call the fire department.
- C. Use only your hand to push in or turn the gas control knobs. Never use tools. If a knob will not push in or turn by hand, don't try to repair it, call a qualified service technician. Force or attempted repair may result in a fire or explosion.
- D. Do not use this control or any gas appliance if any part has been under water or in contact with water. Immediately call a qualified service technician to replace the control system and any gas control system which has been under water or in contact with water.

**Note:** Periodic visual check of the pilot and burner flames is recommended. Refer to the Illustration below at left showing pilot flame and at right to see the proper flame pattern when the Flatfire is lit. The flames should span vertically across the fireplace. The height level will vary depending on the flame adjustment setting.

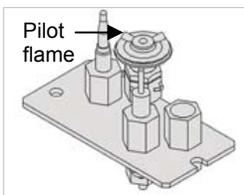

**WITTUS**  
FIRE BY DESIGN

### LIGHTING INSTRUCTIONS

1. **STOP!** Read the safety and warning information at left.
2. **SET THE ELECTRONICS CODE.** For the first time use only – the receiver on the battery pack has to learn the code of the remote control handset. To do this press and hold the receiver's "RESET" button until you hear two (2) acoustic signals. Then, after a longer signal, release the reset button. Within the next 20 seconds press the small flame button (🔥) on the remote until you hear an additional long signal confirming the code is set.
3. **SET ON/OFF SWITCH (1) TO "OFF" POSITION** (on control valve unit shown below). Wait five (5) minutes to clear out any gas, then smell for gas, including near the floor. **If you smell gas, STOP! Follow step 2. in the safety information at left on this page.** If you don't smell gas, go to one of the next steps, namely step 4 using the touch panel, step 5 using the remote, or step 6 using the valve (manual).

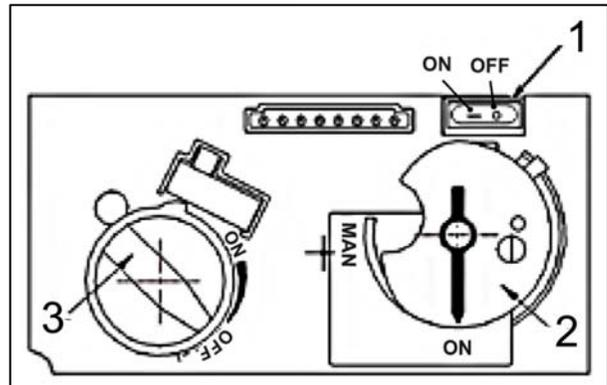

4. **AUTOMATIC IGNITION – Using Touch Pad**
  - a. Locate the pilot inside at the center of the firebox. On the control valve shown above, set the ON/OFF switch (1) to "ON" position, the MAN-knob (2) to "ON" position; and the Flame Adjustment knob (3) to lowest setting (∪).
  - b. On the touch pad shown at right located on right of the fireplace, press and hold red button (B) until a short acoustic signal confirms the start has begun and continuing signals indicate the ignition is in progress.
  - c. Once pilot ignition is confirmed, there is main gas flow.

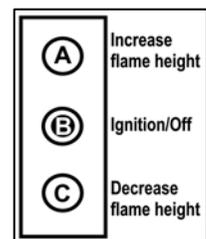

# Flatfire

## Direct Vent Gas Fireplace

### 5. AUTOMATIC IGNITION – Using the Remote

- Locate the pilot inside at the center of the firebox. On the control valve shown on the previous page, set the ON/OFF switch (1) to “ON” position, the MAN-knob (2) to “ON” position; and Flame Adjustment knob (3) to lowest setting (U).
- On the remote control handset (shown below), press the star button (★) and large flame button (🔥) simultaneously; a short acoustic signal confirms the start has begun.
- Further short acoustic signals indicate the ignition process is in progress. When the pilot is lit, the Flame Adjustment knob will automatically rotate to the highest setting.
- Press the small flame button (🔥) on the remote control handset to reduce the flame height.

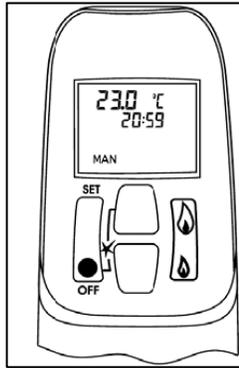

### 6. MANUAL IGNITION

- With the window off, locate the pilot at the center inside of firebox. Refer to the control valve shown on the previous page and set ON/OFF switch (1) to “ON” position, MAN-knob (2) to “MAN” position, and Flame Adjustment knob (3) to lowest setting (U).
- Push down the metallic core with a pen or similar instrument to establish the pilot gas flow. Light gas at the pilot with a match.
- Continue holding down metal core for about 10 seconds; after release, pilot should remain lit. If the pilot will not stay lit after several tries, turn the gas control knob (1) to OFF (U) and call your local service technician or gas supplier.
- If the pilot is lit, reinstall the window and set the MAN-knob (2) to “ON” and turn Flame Adjustment knob (3) up (U) or down (U) manually or use the flame buttons on the remote control to adjust the flame height.

### FLAME HEIGHT ADJUSTMENT

- On the touch pad (illustrated on previous page) press button (A) to increase the flame height or press button (C) to decrease the flame height or set at pilot flame. For fine adjustment tap the button (A) or (C).
- On the remote control handset press the large flame button (🔥) to increase the flame height or press the small flame button (🔥) to decrease the flame height or set at pilot flame. For fine adjustment, tap the large/small flames. For quick flame adjustment press the large or small flame button for 1 second to set to high fire or pilot flame.
- The flame can also be adjusted by raising or lowering the Air Control handle on the right hand side of the firebox.

### TO TURN OFF APPLIANCE

- AUTOMATIC SHUT-OFF** (using the touch pad - shown on previous page): Press the red dot (●) button (B) on the touch pad to shut-off the appliance, including pilot flame.
- AUTOMATIC SHUT-OFF** (using the remote control handset): Press and hold the small flame button on the remote control handset to shut-off the main burner gas flow. Press the red dot (●) button on remote to shut-off the appliance, including pilot flame.
- MANUAL SHUT-OFF** (using the using control valve as shown on the previous page): Press on the ON/OFF switch (1) to OFF to shut-off the appliance, including pilot flame.
- TO TURN OFF THE GAS SUPPLY TO THE APPLIANCE**, close the shut-off valve on the gas supply line to the appliance.

### SETTING THE TIME ON THE REMOTE

- The display on the remote control handset can either be a Fahrenheit/12 hour clock or a Celcius/24 hour clock. To change the setting press OFF and the small flame button on the remote until the display changes.
- To set the time on the remote, first note that the display is flashing (either when the battery is changed or by pressing both the large and small flame buttons simultaneously).

Press the large flame button to set the hour and the small flame button to change the minute. Press OFF to return to manual mode or simply wait and it will automatically return to the manual mode.

# Flatfire

## Direct Vent Gas Fireplace

### SETTING THE TEMPERATURE/TIMER

Using the remote you can set the desired temperatures for daytime and evening and the timers when the fireplace should be on.

#### Changing the Mode of Operation

Briefly press the **SET** button to change the mode of operation in the following order (see examples below):

**MAN** → **☀TEMP** → **🌙TEMP** → **TIMER** → **MAN**



**MAN** Manual Mode – can also be reached by pressing the large or small flame on the remote. Refer to the section on Flame Height Adjustment on page 21 for directions on manually changing the flame height from the remote.

**☀TEMP** Daytime Temperature Mode – (Appliance must be in standby mode, pilot ignited). The room temperature is measured and compared to the set temperature. The flame height is then automatically adjusted to achieve the Daytime set temperature.

**🌙TEMP** Nighttime Setback Temperature Mode – (Appliance must be in standby mode, pilot ignited). The room temperature is measured and compared to the Nighttime Setback temperature. The flame height is then automatically adjusted to achieve the Nighttime Setback temperature.

#### Setting the Temperature

Select either the **☀TEMP** mode or the **🌙TEMP** mode by briefly pressing the SET button. Hold the SET button until the TEMP display flashes. Set the desired temperature with the large flame or small flame buttons. (Note: 40°F/4°C is the minimum temperature setting.)

Press the OFF button or simply wait and the display will go to the temperature control mode. If you would like the Nighttime Setback temperature control to turn off, decrease the **🌙TEMP** mode setting until “----” appears on the display.

Your fireplace will reach the set temperatures and the remote handset will check the temperature every five minutes, adjusting the amount of fuel needed to give you a steady, even heat. The display must remain in **TEMP** mode on the remote. Be patient with settings as it can take a few seconds to program.

Note: Display shows the set temperature every 30 seconds.

**TIMER** Timer Mode – (Appliance must be in standby mode, pilot ignited). The Timer setting allows you to set two (2) burner **☀TEMP** times and two (2) burner **🌙TEMP** times every 24 hours. For **🌙TEMP** to operate as a thermostat, TEMP must be set at 40°F/4°C or higher. Otherwise, the motor will turn the valve to standby position in the night/moon times and await the next day/sun cycle.

#### Setting the Timer

It is possible to program two periods of time per day at which your fireplace will turn on and off automatically.

Select **TIMER** mode by briefly pressing the SET button. Press and hold the SET button until **TIMER** is displayed on the lower right hand side (see illustration at left). Press and hold the SET button until P1 ☀ and the time display flashes. Set the start time by pressing the large flame button for the hour and the small flame button for the minutes.

Then, briefly press SET to P1 🌙 and set the stop time in the same manner you just set P1 ☀ time. Briefly press the SET button again for the next burner cycle time, which will be P2 ☀ and P2 🌙.

If you wish to set only one time period at which your fireplace will turn on and off, program P2 ☀ start time and P2 🌙 stop time for the same time as P1 🌙 stop time.

For example, you can set your fireplace to turn on in the morning just before you get up (P1 ☀ start time) and to turn off when you leave for the day (P1 🌙 stop time). Then, you can set your fireplace to turn on again at the end of the day (P2 ☀ start time) and to turn off when you go to bed at night (P2 🌙 stop time).

Once all four times are set, press **OFF** or simply wait to complete programming. The remote handset must remain in **TIMER** mode to function automatically.

#### Maintenance

A qualified service agency should conduct an annual inspection and maintenance of your Flatfire including the overall installation and venting to keep it running safely. The following procedures should be performed only by a qualified service person. The gas supply should be turned off and the stove should be completely cool whenever a maintenance procedure is performed. All parts of the appliance that are removed for servicing must be replaced prior to operation.

# Flatfire

## Direct Vent Gas Fireplace

**WARNING:** Do not operate the appliance with the glass front removed, cracked or broken. Replacement of the glass should be done by a qualified service person.

**WARNING:** Use only approved Flatfire glass assembly, which includes the glass panel, frame and gasket. Do not use substitute materials. Do not strike or slam the glass front. The appliance area must be kept clear and free from combustible materials, gasoline and other flammable vapors and liquids.

### REPLACING THE GLASS

The glass mounting system consists of the glass panel, special glass gasket and the metal glass frame. Should the glass need to be replaced, you must replace the entire glass/glass frame assembly.

Use the following procedure and refer to the assembly section on page 16 of this manual:

1. Turn the fireplace completely off and allow it to cool to room temperature. Remove the fireplace surround. If the glass is broken, be sure to wear gloves and eye protection.
2. Unclip the sides on the glass frame to free the glass. The glass may be loose in the frame, so it is very important to support both the glass and the frame when handling. Carefully lift the glass frame and glass up and off the fireplace.
3. Set the glass and frame aside on a padded surface. If the glass is broken, do this over spread out newspaper to catch all loose material. Wrap the old glass frame, glass and gasket in layers of newspaper and discard.

### INSTALLING REPLACEMENT GLASS/FRAME

1. Unpack the new glass/glass frame assembly taking care when handling. Carefully pick up the glass and glass frame assembly by grasping the sides of the frame and using your thumbs and fingers to hold the glass in place within the gasket and frame.
2. With the glass frame (and glass) at a slight angle (leaving room for your fingers between the frame and firebox) insert the bottom edge of the frame into the frame retainer located on the bottom front of the firebox. Center the frame from left to right. Once the bottom edge is in place, press the frame against the firebox while pushing down to be sure the frame is fully engaged in the frame retainer. Hold the frame in place and press it against the firebox and clip in the sides. Replace the fireplace surround.

### CLEANING THE GLASS

**WARNING:** Never clean the glass while it is hot. Do not use abrasive cleaners or cleaners containing ammonia.

**NOTE:** The glass manufacturer recommends using a micro-fiber cleaning cloth and plain water for both inside and outside of the glass.

### INSPECTING THE VENTING

An inspection of both the inner and outer vent pipes and the vent terminal should be made as part of the annual service appointment. The venting must have no blockage and be in good repair.

The vent manufacturer's instructions may provide specific details on vent inspection. Any vent sections that are disassembled must be reassembled and sealed as required.

**This appliance should be inspected before use and at least annually by a qualified service person. More frequent cleaning may be required due to excessive dust or lint from carpeting, bedding materials, pets, etc. It is imperative that control compartments and circulating air passageways of this appliance be kept clean.**

### CLEANING THE BURNER AND FIREBOX

During the annual inspection and maintenance appointment, the service person should clean the burner and firebox. To gain access to the firebox and burner, follow the instructions in the Assembly section of this manual.

**DO NOT USE A VACUUM CLEANER TO CLEAN THE GLASS BURNER MEDIA.**

A vacuum cleaner may be used to clean the metal parts of the firebox. Leave the glass burner media in place. Use a soft brush to clean the burner glass media. If the burner media does need to be removed, carefully scoop it off the burner and avoid dropping glass pieces in the air gaps around the burner. Follow the instructions in the Assembly section of this manual when replacing the burner media on the burner top.

### AIR FLOW

The Flatfire utilizes a convection air heat exchange system to maximize the heat from the fireplace. It is important that air flows freely through the convection air system and out the top and side air grills.

**Do not place objects under the fireplace that will block the convection air inlet flow or in front of any air outlet.**

# Flatfire

## Direct Vent Gas Fireplace

### Spare Parts

Part Name	Part #	Part Name	Part #
Maxitrol Gas Combi-control valve - NG	F-GV60M1-N	Crushed Glass Media - Black	F-Fire-Glass-B
Maxitrol Gas Combi-control valve - LP	F-GV60M1-L	Touch up Paint – Black/Gray	F-Paint-B/G
Maxitrol Remote Handset	F-GV-Remote	Gasket Set	F-Gasket
Sit Pilot Assembly	F-SIT-PA	Ceramic Glass	F-Glass
Pass-thru Orifice – NG/LP	F-Orifice-N/L	Outer Frame - Black	FOFA-B
Firebox Panel	F-Firebox	Outer Frame - Gray	FOFA-G
Ceramic Backing Plate - Back	F-I2300-R A	Outer Frame – Stainless Steel	FOFA-ST
Ceramic Backing Plate - Top	F-I2300-R B	Inner Frame	FIFA
Firebox Insulation	F-Skamol	Connector Collar	F-Collar

### Warranty

If you have a problem with this unit, please contact your dealer or supplier immediately. Under no circumstances should you attempt to service the unit in any way by yourself. The warranties in paragraphs 1 and 2 are provided only to the first purchaser/user of this unit, are not transferable and are subject to the conditions and limitations in paragraph 3. Please review the conditions and limitations carefully and strictly follow their requirements.

#### 1. Extended Warranty Coverage

For a period of up to ten (10) years, Wittus Inc. (the “Company”) or its appointed distributor will at its option pay the initial purchaser for the repair of, or will exchange the following parts or components which are found to be defective in material or workmanship under normal conditions of use and service:

- a. Corrosion of frame
- b. Corrosion of firebox or heat elements
- c. Loss of structural integrity of glass.

#### 2. Two-Year Parts Warranty

In addition, for two (2) years from the date of purchase, the Company, at its option, can repair or exchange all parts and components not listed above but that are found to have a *bona fide* defect in material or workmanship under normal conditions of use.

#### 3. Conditions and Limitations

- a. The Installation Record (on the following page) must be completed by the initial owner and returned to the Company within 90 days of purchase.
- b. Installation and maintenance must be performed by an authorized and trained dealer in accordance with the Company’s installation instructions.
- c. This warranty is void where installation of the unit does not conform to all applicable codes including national and local gas appliance installation codes and building and fire codes.
- d. The owner must comply with all operating instructions.
- e. The Company is not responsible for the labor costs to remove defective parts or re-install repaired or replacement parts.
- f. The first purchaser or user of the unit will be responsible for any shipping charges for replacement parts as well as travel time incurred by the dealer to perform the warranty work.
- g. This warranty applies to non-commercial use and service and is void if it is apparent that there is abuse, misuse, alteration, improper installation, accident or lack of maintenance to the unit.
- h. This warranty does not cover damage to the unit through:
  - i. Improper installation, operational or environmental conditions.
  - ii. Inadequate ventilation in the area or competition for air from other household equipment or appliances.
  - iii. Damage due to chemicals, dampness, condensation, or sulfur in the fuel supply lines which exceeds industry standards.
  - iv. This warranty does not cover glass, fireplace liner, or damage to the unit while in transit.

# Flatfire

## Direct Vent Gas Fireplace

### Installation Record

The installer should complete the form below that describes the details of the installation of the Flatfire. Having this written record of installation information available will greatly expedite trouble-shooting should any problem arise with your stove. The installer should keep a duplicate of this form for their records, and a copy should be returned to Wittus Inc.

<u>Installation Record</u>			
Date Purchased:	_____		
Dealer:	_____		
Installer:	_____		
Flatfire Serial Number:	_____		
Date Installed:	_____		
Fuel:	Natural Gas <input type="checkbox"/>	Liquid Propane Gas <input type="checkbox"/>	
Inlet Pressure measured after Installation:	_____	" wc	
Manifold Pressure measured after Installation:	High Fire: _____	" wc	
	Low Fire: _____	" wc	
Venting:			
Vent Brand:	Simpson DuraVent GS/Pro® <input type="checkbox"/>	Selkirk Direct-Temp® <input type="checkbox"/>	EXCELDirect <input type="checkbox"/>
	AmeriVent Direct™ <input type="checkbox"/>	Metal Fab Direct Vent <input type="checkbox"/>	
Vent Termination Cap Model #:	_____	Horizontal <input type="checkbox"/>	Vertical <input type="checkbox"/> Snorkel <input type="checkbox"/>
Configuration:			
Total Horizontal Run:	_____	feet/inches	
Total Vertical Rise:	_____	feet/inches	
Quantity of 90° Elbows:	_____		
Quantity of 45° Elbows:	_____		
Altitude:	_____	feet above sea level	
Was fireplace derated?	_____ Y or N	If Y (yes), to what Orifice size?	_____
Notes:			
Describe unusual structure near vent termination, e.g. inside corner, trees/shrubs:	_____		
	_____		
Other Installation notes, e.g. prevalent wind conditions:	_____		
	_____		