



INSTALLATION AND OPERATION MANUAL

DAVE LENNOX
signature
COLLECTION™

Catalytic Vent-Free Wall-Mounted Gas Fireplace

Models: Radium-NG and Radium-LP

P/N 850,054M REV. B, 03/2008

**Installer: Leave This Manual With The Appliance.
Consumer: Retain This Manual For Future Reference.**

A Spanish manual is available upon request. Order P/N 850,054LS.

Este manual está disponible en español por solicitud. Pida P/N 850,054LS para la versión en español.

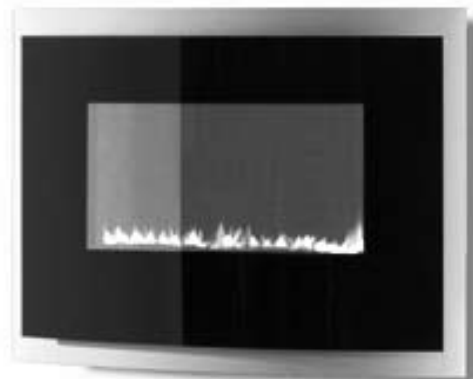

Radium™

In the Commonwealth of Massachusetts:

- Installation must be performed by a licensed plumber or gas fitter
- See Table of Contents for location of additional Commonwealth of Massachusetts requirements

Tested & Listed By  Beaverton Oregon USA
OMNI-Test Laboratories, Inc.
Report No. 317-S-04-5

WARNINGS



- **Hot! Do not touch!** This appliance will be hot during operation and will retain heat for a while after shutting off the appliance. Severe burns may result.
- Carefully supervise children in the same room as appliance.
- Due to high temperatures, the appliance should be located out of traffic and away from furniture or draperies.
- Do not place clothing or other materials on or near this appliance.
- Improper installation, adjustment, alteration, service or maintenance can cause injury or property damage. Refer to this manual. For assistance or additional information consult a qualified installer, service agency or the gas supplier.
- Do not build a wood fire. Do not burn wood or other material in these appliances.
- This is an unvented gas log appliance. It uses air (oxygen) from the room in which it is installed. Provisions for adequate combustion and ventilation air must be provided. Refer to Combustion and Ventilation Air Section in this manual.
- This appliance may be installed in an aftermarket, permanently located, manufactured (mobile) home, where not prohibited by local codes.
- The appliance is only for use with the type of gas indicated on the rating plate. This appliance is not convertible for use with other gases.
- Lennox™ vent-free appliances are designed for use as a supplemental heater. They are not intended for continuous use as a primary heat source.

WARNING: If the information in this manual is not followed exactly, a fire or explosion may result causing property damage, personal injury or loss of life.

Do not store or use gasoline or other flammable vapors or liquids in the vicinity of this or any other appliance.

WHAT TO DO IF YOU SMELL GAS

- Do not light any appliance.
- Do not touch any electrical switches; do not use any phone in your building.
- Immediately call your gas supplier from a neighbor's phone. Follow your gas supplier's instructions.
- If your gas supplier cannot be reached, call the fire department.

Installation and service must be performed by a qualified installer, service agency or the gas supplier.

1.0 IMPORTANT SAFETY AND WARNING INFORMATION



WARNINGS

If the information in this manual is not followed exactly, a fire or explosion may result causing property damage, personal injury or loss of life.



IMPORTANT

Read and understand these instructions completely before installing or operating your unvented room heater.

WARNING

Failure to keep the primary air opening(s) of the burner(s) clean may result in sooting and property damage.

WARNING

Failure to comply with the installation and operation instructions provided in this document will result in an improperly installed and operating appliance, voiding its warranty. Any change to this appliance and/or its operating controls is dangerous. Improper installation or use of this appliance can cause serious injury or death from fire, burns, explosion or carbon monoxide poisoning.

WARNING

Do not allow fans to blow directly into the fireplace. Avoid any drafts that alter burner flame patterns.

WARNING

Check gas type: The gas supply must be the same as stated on the appliance's rating plate. If the gas supply is different DO NOT install the appliance. Contact your dealer for the correct model.

WARNING

Do not use a blower insert, heat exchanger insert or other accessory not approved for use with this heater.

- Children and adults should be alerted to the hazard of high surface temperature and should stay away to avoid burns or clothing ignition.
- Young children should be carefully supervised when they are in the same room with the heater.
- Do not place clothing or other flammable material on or near the heater.
- Any safety screen or guard removed for servicing the heater must be replaced prior to operating the heater.
- Installation and repair should be done by a qualified service person. The heater should be inspected before use and at least annually by a professional service person. More frequent cleaning may be required due to excessive lint from carpeting, bedding material, etc. It is important that control compartments, burners and circulating air passageways of the heater be kept clean.
- Allow the heater to cool before servicing. Always shut off the gas to the heater while performing service work.
- The installation must conform with local codes or, in the absence of local codes with the National Fuel Gas Code, ANSI Z223.1/NFPA 54-latest edition.
- The heater and its individual shut-off valve must be disconnected from the gas supply piping system while performing any tests of the gas supply piping system at pressures in excess of 1/2 psig.
- The heater must be isolated from the gas supply piping system by closing its individual manual shut-off valve during any pressure testing of the gas supply piping system at test pressures equal to or less than 1/2 psig.
- Keep heater area clear and free from combustible materials, gasoline and other flammable vapors and liquids.
- Do not use this heater if any part has been under water. Immediately call a qualified service technician to inspect the room heater and to replace any part of the control system and any gas control which has been under water.
- Input ratings are shown in BTU per hour and are for elevations up to 4,500 feet. Do not install this heater at an elevation above 4,500 feet if the gas supply has not been derated for that elevation. Consult your local gas supplier. (For operation at elevations above 4,500 feet, equipment ratings shall be reduced at the rate of 4 percent for each 1,000 feet above 4,500 feet before selecting appropriately sized equipment). When installing any vent-free appliance at elevations above 4500 feet, nuisance pilot outages may occur.
- Ensure that the heater is clean when operating. Excessive dust accumulation on the burner will increase the amount of carbon monoxide formation and could lead to carbon monoxide poisoning and/or death.
- This appliance is intended for supplemental heating.
- Carbon monoxide poisoning – early signs of carbon monoxide poisoning resemble the flu with headaches, dizziness, or nausea. If you have these signs, get fresh air at once! Turn off the gas supply to the appliance and have the heater inspected by a qualified service technician. Some people are more affected by carbon monoxide than others. These include pregnant women, people with heart or lung disease or anemia, those under the influence of alcohol, and those at high altitudes.
- Maintain minimum clearances.
- Do not install the appliance in a sleeping room or bathroom.

CONGRATULATIONS ON THE PURCHASE OF YOUR NEW GAS APPLIANCE MANUFACTURED BY LENNOX HEARTH PRODUCTS.

When you purchased your new gas fireplace, you joined the ranks of thousands of individuals whose answer to their home heating needs reflects their concern for efficiency and our environment. We extend our continued support to help you achieve the maximum benefit and enjoyment available from your new gas fireplace. It is our goal at Lennox Hearth Products to provide you, our valued customer, with an appliance that will ensure years of trouble-free warmth and pleasure.

Thank you for selecting a Lennox Hearth Products gas fireplace as the answer to your supplemental home heating needs.

Sincerely, All of us at Lennox Hearth Products

TABLE OF CONTENTS

| Section | Contents | Page No. |
|---------|---|----------|
| 1.0 | Safety And Warning Information | 2 |
| 2.0 | General Information | 3 |
| 3.0 | Packaging List | 3 |
| 4.0 | Appliance Specifications | 3 |
| 5.0 | Burn-in Period | 4 |
| 6.0 | Codes, Massachusetts & New York | 4 |
| 7.0 | Combustion And Ventilation Air | 5 |
| 8.0 | Site Requirements | 6 |
| 9.0 | Preparing The Appliance | 6 |
| 10.0 | Mounting The Appliance | 7 |
| 11.0 | Checking The Burner | 8 |
| 12.0 | Connecting A Gas Line | 8 |
| 13.0 | Checking The Gas Connections | 9 |
| 14.0 | Gas Pressure Check | 9 |
| 15.0 | Spark Gap | 10 |
| 16.0 | Fitting The Glass Facia | 10 |
| 17.0 | Briefing The Customer | 10 |
| 18.0 | Servicing | 11 |
| 19.0 | Servicing The Burner | 11 |
| 20.0 | Pilot Assembly | 11 |
| 21.0 | Catalysts | 12 |
| 22.0 | Testing For Firebox Leakage | 12 |
| 23.0 | Cleaning | 12 |
| 24.0 | Lighting Instructions & Turning Off Appliance | 13 |
| 25.0 | Troubleshooting Guide | 14 |
| 26.0 | Replacement Parts List | 15 |
| 27.0 | Positioning Of Field Assembled Parts | 16 |
| 28.0 | Notes | 17 |
| 29.0 | Product Reference Information | 18 |

2.0 GENERAL INFORMATION

This appliance is a high efficiency, unvented, flame effect gas heater. It provides radiant and convected warmth both efficiently and safely utilizing the latest type catalytic convertor burner technology. The appliance does not require a flue system of any type as the catalytic converter cleans the flue products to provide a complete combustion system, which is intrinsically safe.

These heaters are fitted with a specially designed pilot utilizing an oxygen depletion sensor (ODS) which responds to the amount of oxygen available in the room and shuts the heater off before the oxygen level drops below 18%. The pilot can be relit only when fresh air is available. Refer to the Combustion and Ventilation Air section.

The appliance is designed to fit various types of situations as listed in the Installation Requirements.

This appliance is factory set for operation on the gas type, and at the pressure stated on the appliance rating plate.

Read all these instructions before commencing installation. All instructions must be handed to the user for safekeeping.

3.0 PACKAGING LIST

| Quantity | Description |
|----------|--|
| 1 | Firebox, Burner & Curved Rear Frame Assembly |
| 1 | Installation and operation instructions |
| 1 | Glass Facia Panel Assembly |
| 1 | Screw And Wall Plug Pack |
| 1 | Rubber Grommet |
| 1 | Fitting Template |
| 1 | Wall Mounting Plate |

4.0 APPLIANCE SPECIFICATIONS

| Gas Type | | Natural Gas | Propane Gas (LP) |
|--|------|-----------------------|-----------------------|
| Gas inlet pressure | Max. | 10.5" w.c. | 13" w.c. |
| | Min. | 6" w.c. | 11" w.c. |
| Regulator Pressure Setting | | 5" w.c. | 10" w.c. |
| Max Energy Input | | 8,870 BTU/hour | 7,500 BTU/hour |
| Min Energy Input | | 5,110 BTU/hour | 5,110 BTU/hour |
| Pilot Energy Input | | 560 BTU/hour | 560 BTU/hour |
| Burner Pressure (manifold) | High | 3.5" w.c. | 5.6" w.c. |
| | Low | 1.1" w.c. | 2.9" w.c. |
| Main burner flow restrictor (burner orifice) | | 1.45mm (0.057") | 1.03mm (0.04") |
| Oxypilot | | SIT/Bray 9082 | SIT/Bray 9284 |
| Gas Inlet Connection | | 3/8" NPT at regulator | 3/8" NPT at regulator |
| Ignition | | Piezo spark | Piezo spark |
| Spark Gap | | 1/8" - 3/16" | 1/8" - 3/16" |

Please see Data Plate affixed to appliance for current data. This appliance is for use only with the gas type, and at the pressure stated on the appliance Data Plate.

Table 1

5.0 BURN-IN PERIOD

On initial light up of a new appliance, the 'newness' will burn off within the first few hours of operation. During this period some smoke may be emitted from outlet grill, this should be no cause for concern. Accordingly, the room should be well ventilated with all windows and doors open during this period.

Depending on your use, the burn-in period may take a few hours or a few days. Also if you have a sensitive sense of smell you may notice slight odors during operating after the burn-in period is over.

KEEP YOUR HOUSE WELL VENTILATED DURING THE BURN-IN PERIOD. THE ODOR AND HAZE EMITTED DURING THE BURN-IN PERIOD CAN BE QUITE NOTICEABLE AND MAY SET OFF A SMOKE DETECTOR. MAKE SURE SMOKE DETECTORS ARE NOT TOO CLOSE TO THE FIREBOX (CHECK WITH YOUR LOCAL CODE FOR ALLOWABLE DISTANCES).

6.0 CODES

Adhere to all local codes or in their absence the latest edition of The National Fuel Gas Code ANSI Z223.1 / NFPA 54 - latest edition which can be obtained from The American National Standards Institute, Inc. (1430 Broadway, New York, NY, 10018) or National Fire Protection Association, Inc. (Battery March Park, Quincy, MA, 02269).

Seller of unvented propane or natural gas fired supplemental room heaters in the Commonwealth of Massachusetts shall provide to each purchaser a copy of 527 CMR 30 upon sale of the unit.

This Lennox Hearth Products Unvented Gas Room Heater is certified by OMNI-Test Laboratories, Inc to ANSI Z21.11.2 standard.

THE FOLLOWING BOXED INFORMATION APPLIES TO REQUIREMENTS FOR THE COMMONWEALTH OF MASSACHUSETTS.

Note: The following requirements reference various Massachusetts and national codes not contained in this document.

Unvented Room Heaters shall be installed in accordance with 527 CMR 30.00 and 248 CMR 3.00 through 7.00:

(a) Permits and Inspections: In addition to complying with 248 CMR 3.05 the following requirements must be satisfied:

1. A permit shall be obtained from the head of the fire department and the local or state gas inspector having jurisdiction for the installation of all unvented propane or natural gas-fired space/room heaters.
2. The permits shall be conditioned upon final inspection and approval of installation by the head of the fire department and the local or state gas inspector having jurisdiction.
3. A copy of the manufacturer's installation/operating literature shall be submitted with each permit application.
4. Before operation, the Head of the Fire Department and the local or state gas inspector shall inspect the installation for compliance with 527 CMR (Board of Fire Prevention Regulations) and 248 CMR (Board of State Examiners of Plumbers and Gas Fitters).
5. (a) A final inspection by the state or local gas inspector of the unvented space/room heater shall not be performed until proof is provided that the head of the fire department having jurisdiction has granted a permit.
(b) Unvented natural gas-fired space/room heaters shall conform to ANSI Z21.11.2, be equipped with an oxygen depletion safety (ODS) shutoff system and be Product-approved in accordance with 248 CMR.
(c) Unvented natural gas-fired space/room heaters shall be installed in accordance with their listings and the manufacturer's instructions. Proper clearances to combustibles shall be maintained. In no case shall the clearances be such as to interfere with combustion air and accessibility.
(d) Installations shall be of a permanent type, with a permanently piped fuel supply in accordance with 248 CMR. LPG appliances shall be subject to the storage requirements in accordance with 527 CMR 6.00. Portable unvented or natural gas-fired space/room heaters shall be prohibited.
(e) Unvented natural gas-fired space/room heaters shall be prohibited in bedrooms and bathrooms.
(f) Space/room heaters shall be properly sized for the room or space of installation, but shall not exceed a maximum of 40,000 BTU input per room or space.
(g) In occupancies with an unvented natural gas-fired space/room heater, no less than one listed carbon monoxide detector that is installed in accordance with the manufacturers instructions shall be installed and maintained near the space where the heater is located.

New York: This appliance is approved for installation in the U.S. state of New York, but not New York City.

7.0 COMBUSTION AND VENTILATION AIR

This heater shall not be installed in a confined space or unusually tight construction unless provisions are provided for adequate combustion and ventilation air. The heater may be located in unusually tight construction provided the space is unconfined, or if confined, is provided with two permanent openings communicating directly with an additional room(s) of sufficient volume so that the combined volume of all connected spaces meets the criteria for an unconfined space, (National Fuel Gas Code NFPA 54 / ANSI Z223.1 - latest edition, Section on *Air for Combustion and Ventilation*. Generally 50 ft³ per 1,000 BTU input of all operating appliances in the space.

The National Fuel Gas Code, ANSI Z223.1/NFPA 54, defines a confined space as a space whose volume is less than 50 ft³ per 1,000 BTU/Hr (4.8 m³ per kW) of the aggregate input rating of all appliances installed in that space and an unconfined space as a space whose volume is not less than 50 ft³ per 1,000 BTU/Hr (4.8 m³ per kW) of the aggregate input rating of all appliances installed in that space.

Rooms communicating directly with the space in which the appliances are installed, through openings not furnished with doors, are considered a part of the unconfined space.

Unusually tight construction is defined as construction where:

- Wall and ceilings exposed to the outside atmosphere have a continuous water vapor retarder with a rating of one perm (6 X 10⁻¹¹ kg per pa-sec-m²) or less with openings gasketed or sealed;
- Weather stripping has been added on operable windows and doors; and
- Caulking or sealants are applied to areas such as joints around window and door frames, between sole plates and floors, between wall ceiling joints, between wall panels, at penetrations for plumbing, electrical, and gas lines, and at other openings.

Use the following equations to determine if you have a confined or unconfined space.

- Determine the volume of space — ft³.

Length x Width x Height = _____ ft³
(Include adjoining rooms with doorless passageways or ventilation grills between rooms).

Example: 24' (L) x 16' (W) x 8' (H) = 3072 ft³

- Divide the volume of space by 50 ft³ to determine the maximum BTU/Hr the space can support.

_____ (volume of space – ft³) / 50 ft³ =
(Maximum BTU/Hr the space can support)

Example: 3072 ft³ / 50 ft³ = 61.44
or 61,440 BTU/Hr the space can support.

- Add the BTU/Hr of all the fuel burning appliances in the space.

| | | |
|--------------------|-------|--------|
| Vent-Free heater | _____ | BTU/Hr |
| Gas appliance #1 * | _____ | BTU/Hr |
| Gas appliance #2 + | _____ | BTU/Hr |
| Gas appliance #3 + | _____ | BTU/Hr |
| Total = | _____ | BTU/Hr |

Example:

| | | |
|------------------------------------|--------|--------|
| Vent-free heater #1 | 9,000 | BTU/Hr |
| Vent-free heater #2 | 23,000 | BTU/Hr |
| Gas appliance #1 (water heater) | 35,000 | BTU/Hr |
| Total = | 67,000 | BTU/Hr |

- * Do not include direct-vent gas appliances. Direct-vent is sealed combustion and draws combustion air from the outdoors.

- Compare the maximum BTU/Hr the space can support with the actual amount of BTU/Hr used.

_____ BTU/Hr (max. the space can support)
_____ BTU/Hr (actual amount of BTU/Hr used)

Example:

| | |
|--------|---------------------------------------|
| 61,440 | BTU/Hr (max. the space can support) |
| 67,000 | BTU/Hr (actual amount of BTU/Hr used) |

The space in the previous example is a confined space because the actual BTU/Hr used is more than the maximum BTU/Hr the space can support. You must provide additional fresh air.

Your options are:

- Rework equations adding the space of adjoining room(s). If the extra volume provides an unconfined space, then remove door or add ventilation grills between rooms. Refer to National Fuel Gas Code, ANSI Z223.1/NFPA 54-latest edition, Section "Air for Combustion and Ventilation".
- Vent room directly to the outdoors. Refer to National Fuel Gas Code, ANSI Z223.1/NFPA 54-latest edition, Section "Air for Combustion and Ventilation".
- Install a lower BTU/Hr heater to make the area an unconfined space.

If the actual BTU/Hr used is less than the maximum BTU/Hr the space can support, then the space is an unconfined space. You will need no additional fresh air ventilation for an unconfined space.

WARNING

If the area in which the heater may be operated is smaller than that defined as an unconfined space or if the building is of unusually tight construction, provide adequate combustion and ventilation air by one of the methods described in the national fuel gas code, ANSI Z223.1/NFPA 54, *Air for Combustion and Ventilation* Or applicable local codes.

8.0 SITE REQUIREMENTS

This appliance is designed to be wall-hung. Do not recess any part of the appliance into the wall.

This appliance may be installed in any room in a home except bathrooms - or areas where large amounts of steam are likely to be generated. This appliance is approved for installation into a bedroom.

It should be noted that heaters create warm air currents. These currents move heat to wall surfaces next to the heater. Installing the heater next to vinyl or cloth wall coverings or operating the heater where impurities in the air (such as tobacco smoke or candle smoke) exist, may discolor walls.

Installation in living rooms is common, however other rooms such as kitchens, dining rooms and hallways are permitted, providing a suitable gas supply is available, and rooms sizing and ventilation requirements are strictly adhered to (see Section 7.0).

The appliance is designed to be versatile, and as such will operate correctly when exposed to normal gentle drafts experienced within the home. It is not recommended, however that the appliance be installed in areas where it is likely to be exposed to persistent strong drafts, that may be generated by outside doors or windows, air vents etc. It is recommended that the appliance should not be installed within 20" of any air vent.

CLEARANCES TO NON-COMBUSTIBLES

Non-combustible surfaces are defined as brick, metal, marble, concrete etc. and also a number of man-made materials impervious to flame. If in doubt refer to the material manufacturer for further information before proceeding with installation.

Clearances to the sides of the appliance are 4". Clearance to the front of the appliance is 20".

The back of the appliance may be installed directly onto a non-combustible wall, providing the area behind the appliance is flat and does not interfere with the various vent holes in the back panel of the appliance.

The appliance may be installed with or without a non-combustible hearth. If a hearth is fitted, the size and design may be as desired.

A non-combustible shelf of any depth may be positioned above the appliance provided it is no closer than 16" from the top of the appliance glass panel and the wall above the appliance is non combustible.

CLEARANCES TO COMBUSTIBLE MATERIALS

Combustible materials are defined as wood, fabrics, or other materials likely to combust if exposed to flame. Generally, any material, which is likely to discolor, melt or misshape when exposed to moderate heat, should be considered as a combustible material or surface.

Clearance to the sides of the appliance are 4" but curtains, drapes and other fabrics are not permitted within a distance of 20" of the appliance sides. No such materials are permitted directly above the appliance regardless of distance.

The minimum clearance to the ceiling above the appliance is 32" measured from the top of the appliance glass panel.

Combustible materials should not be positioned directly in front of the appliance within a distance of 40".

Under no circumstances should any electrical equipment e.g. plasma screen TV sets etc. be positioned on the wall above the appliance. The appliance is designed to be wall mounted alone and not in conjunction with any type of combustible fire surround.

No combustible shelves should be positioned on the wall above the appliance.

It should be established that any mirrors or picture frames etc. to be positioned on the wall above the appliance are able to withstand prolonged exposure to moderate heat and moisture before proceeding with their installation.

The wall must be structurally sound and constructed from a material capable of withstanding moderate heat. Finished plaster, conventional wall paper and dry-lined plasterboard are examples of suitable materials. Materials such as flock, blown vinyl and embossed paper which are sensitive to even small amounts of heat should be avoided as scorching and or discoloration may occur over time.

If the appliance is to be mounted on a dry-lined wall or a timber framed construction wall then the integrity and ability of the wall to carry the weight of the appliance must be confirmed. It is important in these circumstances that any vapor control barrier is not damaged, and that any structural members of the house frame are not damaged.

The appliance may be positioned as close to a solid floor (i.e. stone, wooden laminate etc.) as the particular design of fire frame permits, however it is not permitted to install the appliance within 4" of carpet, rugs or fabric materials of any kind. This dimension is measured vertically to the bottom of the appliance frame.

9.0 PREPARING THE APPLIANCE

The curved rear frame is supplied pre-assembled to the appliance - no further preparation is necessary. Remove the wall mounting plate from the appliance by removal of the two wing-nuts located in the lower inner section of the firebox.

Follow the steps below:

Gas connection: The heater gas inlet connection is 3/8" NPT at the regulator, located below the burner, in the right hand side of the heater. There are four possible entry points for the gas supply pipe-work to enter the appliance firebox. These entry points are 'knock out' type holes (shown in *Figure 1*).

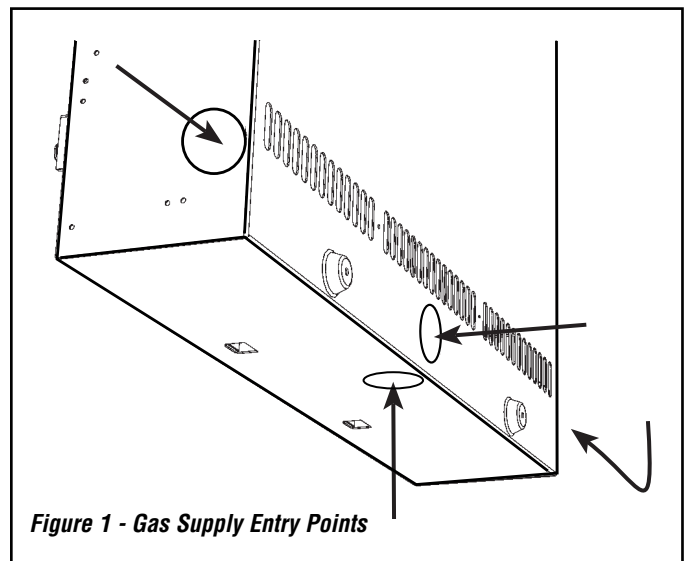

Figure 1 - Gas Supply Entry Points

Non-concealed gas connections may be made using the entry points at either end of the firebox or the one in the bottom of the firebox. A concealed gas connection may be made using the knock out hole in the center back of the firebox. Select the most appropriate entry point and knock out the relevant hole.

If a concealed gas connection is to be made, the supply pipe should always be sleeved through walls and floors using the shortest possible route.

For concealed supply pipe routing, pipes must (where possible) be vertical and providing there is sufficient wall thickness available, they should be placed in pipe chases. Horizontal pipe runs should be avoided where possible. Prior to chasing a solid wall, an inspection should be made to note the proximity of any cables/sockets outlets which may already be buried. Pipes must be secured using suitable clips and protected against corrosion. Ideally factory finished protected pipe-work and fittings should be used. Joints should be kept to a minimum and compression fittings must not be used. The pipe-work installation must be tested for soundness before any protection is applied and/or the pipe-work and fittings are buried.

10.0 MOUNTING THE APPLIANCE

After having selected the final mounting position of the appliance, taking into account the site requirements as specified in Section 8 of these instructions, the integrity of the wall, and the feasibility of the proposed supply pipe routing, the firebox of appliance may be secured to the wall..

⚠ WARNING

The wall where the appliance is to be installed must be capable of long-term support of the total load of the appliance. Measures should also be taken to ensure sufficient strength to withstand the force of earthquakes, vibration and other external forces.

To ensure customer safety, be sure to design the installation so that the strength of both the wall and any wall fixings used are sufficient. Lennox Hearth Products assumes absolutely no responsibility for injuries and damages that may occur due to improper installation or handling.

The appliance should not be installed until all dry wall sanding and wall painting has been completed.

Incorrect installation can cause the appliance to fall from the wall and cause injury. Do not block the ventilation holes of the appliance. The wall onto which the appliance is installed must be flat. Install only on a vertical surface. Avoid sloped surfaces. **Installation onto anything other than a vertical wall may result in fire, damage or injury.**

A full size fitting template is supplied to assist with wall mounting.

If the heater is to be installed on a studded wall with conventional 16" stud spacing then a wall mounting plate is supplied to enable this. First locate the studs and using suitable fixings, screw the mounting plate to the wall via the four mounting holes. The heater may then be hung onto the mounting plate. The bottom of the heater may be secured onto the lower mounting studs using the wing-nuts or the hex nuts provided.

Mark the positions shown as "Fixing Points" on the wall. If the appliance is to be mounted on the inner leaf of a conventional cavity wall, or a solid wall, drill four holes using a 5/16" masonry bit, to a depth of 1-11/16". Insert the wall plugs provided.

If the appliance is to be mounted on a dry lined wall or a timber framed construction wall then special cavity screw fixings will be required which are not supplied with this product. These should be constructed from metal and not plastic.

If a concealed gas connection is to be made ensure the gas supply pipe is in it's final position and can enter the appliance in the correct position when the appliance is hung on the wall.

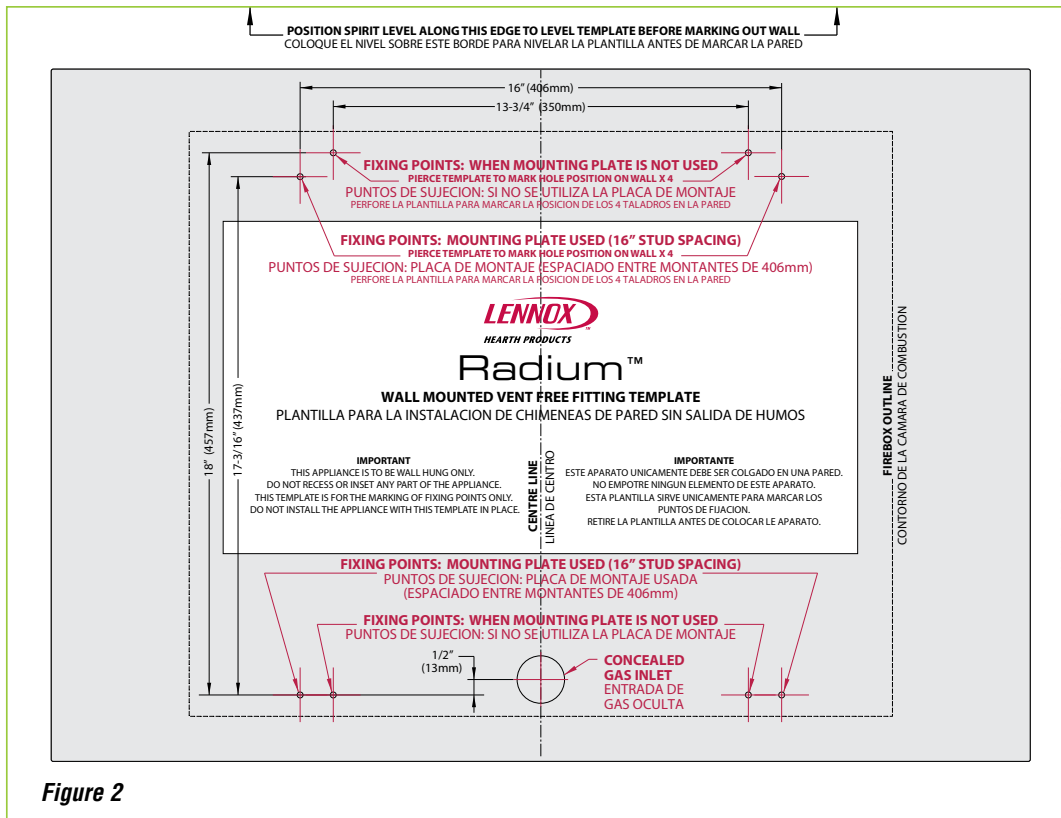

Figure 2

10.0 MOUNTING THE APPLIANCE - continued

Insert the wall mounting screws into the top wall plugs, taking care to leave the screws protruding approximately 3/8" from the wall. Now hang the appliance onto these screws through the two keyhole shaped holes in the back panel of the appliance.

Insert the lower mounting screws into the lower wall plugs through the corresponding depressed holes in the lower part of the back panel. Do not tighten fully.

Before tightening the wall mounting screws fully, at this stage it is recommended to check the horizontal alignment of the appliance with a bubble level, as small adjustments can still be made if necessary. When this has been checked, tighten all four fixing screws fully.

To access the upper fixing screws insert a screwdriver through the holes in the deflector plates above the catalyst as shown in **Figure 3**.

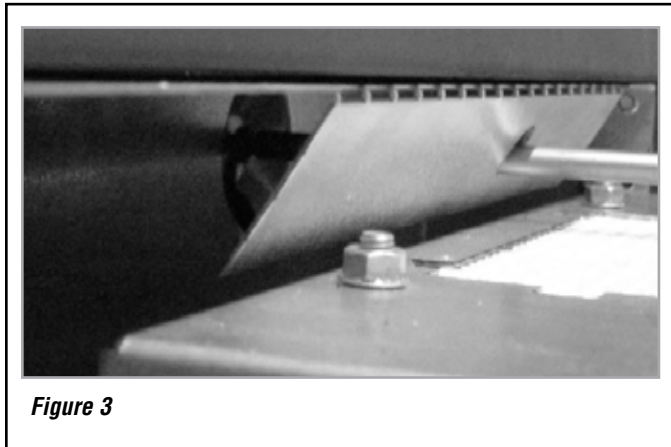

Figure 3

11.0 CHECKING THE BURNER

There are no imitation fuel bed components to install. The appliance features a ribbon burner which is designed to produce a continuous band of flame over its length. The burner should be visually inspected to ensure it is free from any foreign matter. If it is necessary to clean or dust off the burner then the glass door should be removed by removal of the four retaining screws. Re-fit the glass door after cleaning or inspection, ensuring a good seal.

12.0 CONNECTING A GAS LINE

WARNING

Connecting directly to a unregulated propane (L.P.G.) tank may cause an explosion.

IMPORTANT

Hold heater regulator with a wrench to prevent movement when connecting to inlet piping.

A qualified gas appliance installer must connect the gas room heater to the gas supply. Consult all local codes.

The installer must provide an ANSI approved manual shut off valve, flex connector and 3/8" NPT fitting.

Route gas line using techniques and materials prescribed by local and/or national codes. Only use pipe of 1/2" or greater size to allow full gas volume to the gas fireplace. Undue pressure loss will occur if the pipe is too small.

An external regulator must be used on all propane (L.P.G.) heaters, in addition to the regulator fitted to the heater, to reduce the supply tank pressure to 13" w.c. (maximum).

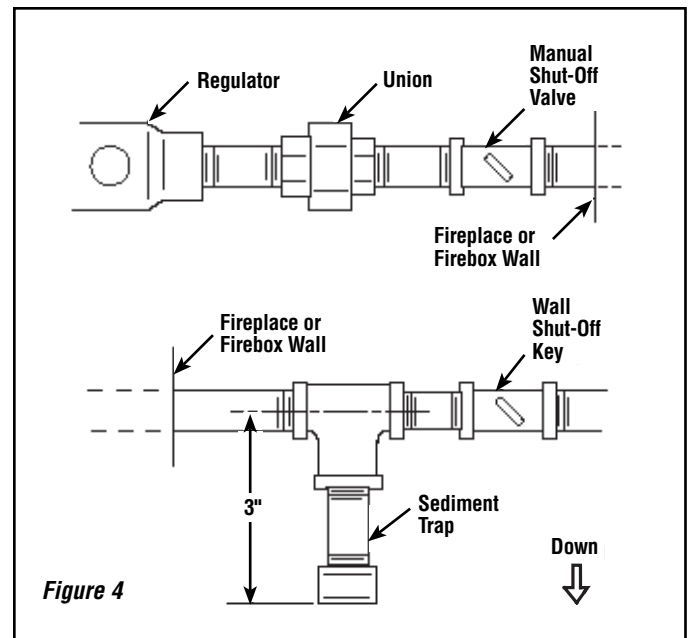

Figure 4

An ANSI approved manual shut-off valve and union must be installed upstream of the heater within the fireplace cavity when rigid pipe is used. Ensure that a sediment trap is installed upstream of the heater (**Figure 4**) within the structure's piping system to prevent moisture and contaminants from passing through the pipe to the heater controls and burner. Failure to do so could prevent the heater from operating reliably.

The heater gas inlet connection is 3/8" NPT at the regulator, located below the burner, in the right hand side of the heater. When tightening up the joint to the regulator hold the regulator securely with a wrench to prevent the regulator from moving.

13.0 CHECKING THE GAS CONNECTIONS

WARNING

Never use an open flame to check for leaks.

Turn on gas supply and test for gas leaks using a gas leak test solution (also referred to as bubble leak solution).

NOTE: using a soapy water solution (50% dish soap, 50% water) is an effective leak test solution, but it is not recommended, because the soap residue that is left on the pipes/fittings can result in corrosion over time.

- A. Light the appliance (refer to the lighting instructions label in the control compartment or on **Page 13**).
- B. Brush all joints and connections with the gas leak test solution to check for leaks. If bubbles are formed, or gas odor is detected, turn the gas control knob (off/pilot/on) to the "OFF" position. Either tighten or refasten the leaking connection, then retest as described above.
- C. When the gas lines are tested and leak free, be sure to rinse off the leak testing solution.
- D. Observe the individual tongues of flame on the burner. Make sure all ports are open and producing flame evenly across the burner. If any ports are blocked, or partially blocked, clean out the ports.

14.0 GAS PRESSURE CHECK

The heater regulator controls the burner pressure which should be checked at the pressure test points located on the control valve itself (shown in **Figure 5**) for burner (manifold) and regulator (inlet) setting pressures.

The valve is found on the center of the appliance behind the valve cover. Remove the cover plate by unscrewing the four retaining screws. Release the test point screws and ensure operating pressures are as specified in **Table 1** on **Page 3** of these instructions. The pressure should be checked with the gas heater burning and the control set to high flame.

The pressure regulator on manual models is preset and locked to avoid tampering. If the pressure is not as specified in **Table 1** on **Page 3**, replace the regulator with P/N H6063 for Natural Gas units and H7001 for Propane Gas units. Replace the test point screws after pressure measurement ensuring no gas leaks. All instructions must be handed to the user for safekeeping.

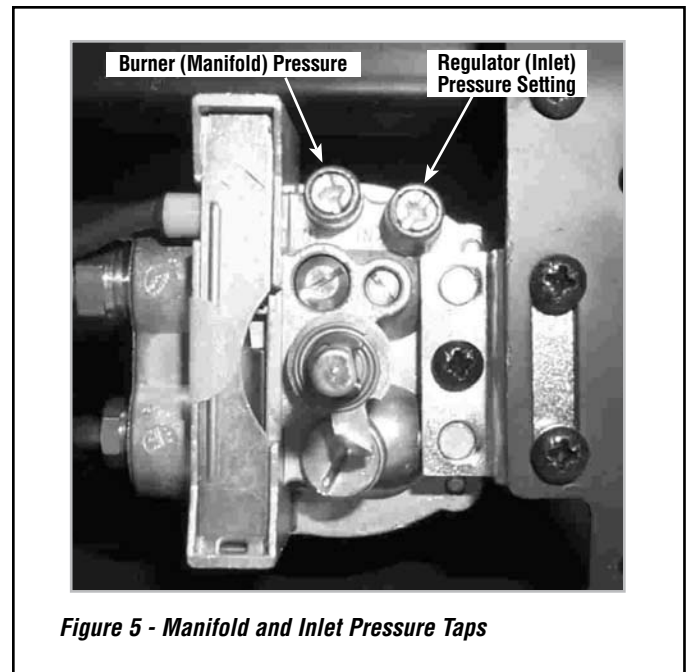

15.0 SPARK GAP

The gap between the spark electrode and the pilot should be 1/8" to 3/16" to produce a good spark. There should be no need to adjust this. If under any circumstances the piezo electric spark fails, the pilot cannot be lit manually.

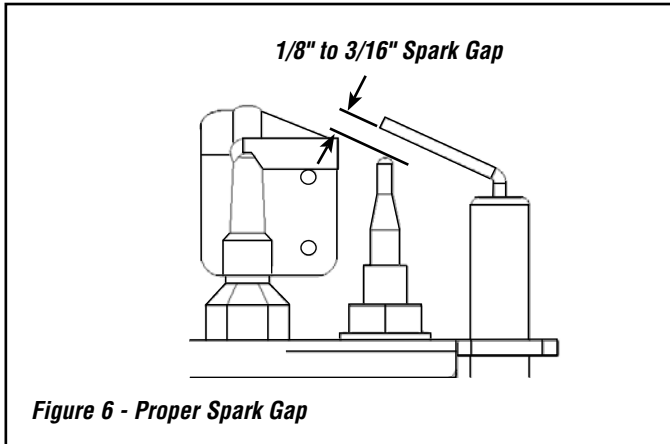

16.0 FITTING THE GLASS FACIA

The glass panel is supported by two self-locking M6 screws, one on each side of the fireplace. The glass panel must be held in position while the screws are inserted on each side - it is recommended to seek assistance for this operation. See **Figure 7a**. The screws should be screwed in fully and then undone one turn to allow the glass panel to swing open for access to the controls.

The appliance features a piston damper hinge assembly. The damper assembly should be fitted onto the rear of the glass facia, on the lower right hand side as follows:

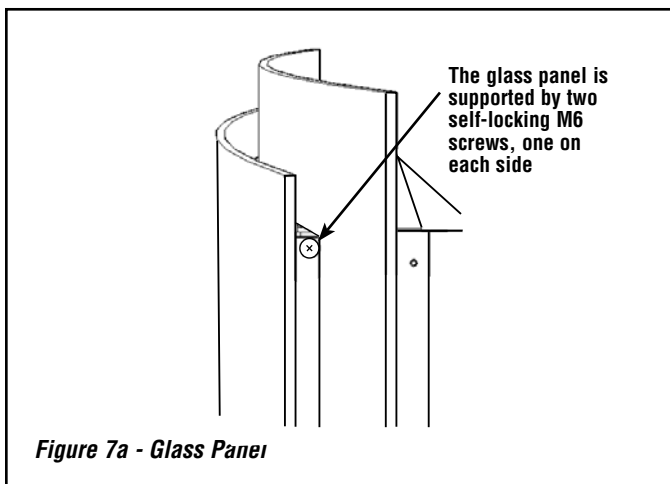

1) Ensure that the piston portion of the damper is positioned as shown in **Figure 7b**. Remove the Philips screw securing the frame, and fit the lower piston bracket to the frame and fully re-tighten the screw.

Now fit the lower piston bolt through the hole in the bracket, with the two nylon washers positioned either side of the bracket. Finally, attach the "nyloc nut" to the damper thread, tighten and then release one quarter turn. Check that the assembly can swivel.

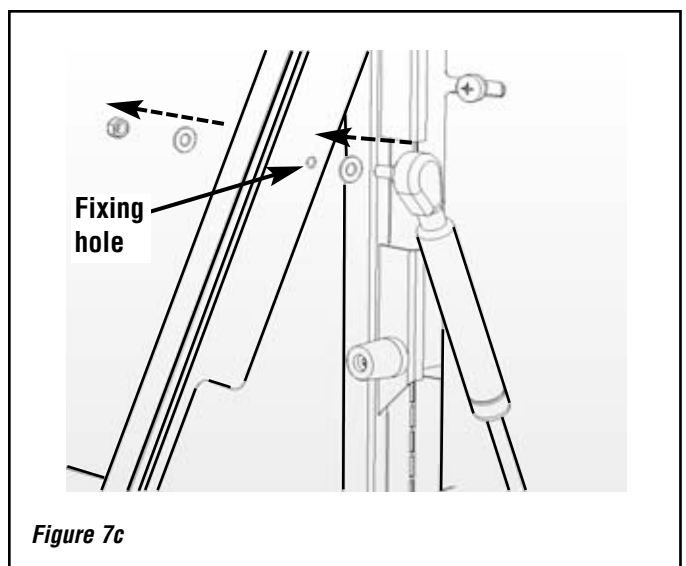
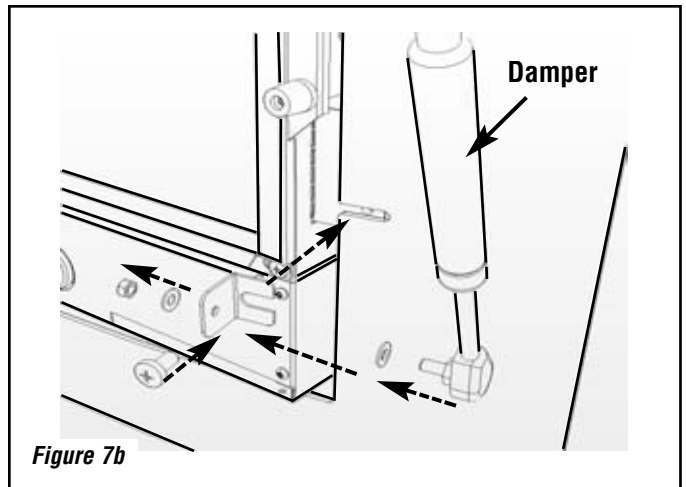

17.0 BRIEFING THE CUSTOMER

! WARNING

Do not add logs or ornaments such as pine cones, vermiculite or rock wool. Using these added items can cause sooting.

All instructions must be handed to the user for safekeeping. Show the customer how to light and control the fire. Show the customer how to remove and replace the glass facia.

After commissioning the appliance, the customer should be instructed on the safe use of the appliance and the need for regular servicing. Frequency of service depends on usage, but **MUST** be carried out at least once annually. Advise that cleaning of the fire may be achieved when the fire is cold using a damp cloth and mild detergent on most surfaces.

Advise that the fire will emit a "newness" smell for a time after initial commissioning and that extra ventilation may be needed during this time. Recommend that a guard be used for the protection of the young, pets, the elderly and the infirm.

A periodic visual check of the pilot flame and the burner flame should be carried out.

18.0 SERVICING

WARNING

Turn off the appliance and allow to cool before cleaning. Verify proper operation after servicing.

Turn off the fireplace at the gas supply. Ensure that the fireplace is fully cold before attempting service. A suggested procedure for servicing is detailed as follows;

1. Lay out the dustsheet and tools.
2. Remove the front glass facia as described in Section 16.0, only in reverse.
3. Remove the glass door assembly (4 screws) and clean carefully. Remove the valve cover plate (4 screws).
4. Inspect the burner and the catalysts and clean if necessary with a soft brush.
5. Disconnect the gas supply.
6. Undo the four screws retaining the burner support brackets.
7. Remove the burner unit, strip off the burner pipes and clean thoroughly.
8. Clean the in-line restrictor, pilot assembly and the burner tube. Do not attempt to remove the pilot injector as this can cause damage.
9. Re-assemble components.
10. Re-connect the gas supply. Turn on the gas supply and perform a gas leak test using gas leak test solution. Check pilot and burner for good ignition.
11. Refit the valve cover and retaining screws.
12. Refit the glass door assembly.
13. Refit the facia as described in Section 16.0.
14. Check the purpose provided ventilation is unobstructed.
15. Light the fire and test setting pressures.
16. Check safe operation of the appliance.

For specific servicing instructions, see relevant sections.

19.0 SERVICING THE BURNER

WARNING

Any change to this heater or its controls can be dangerous.

WARNING

You must keep control areas, burners and circulating air passageways of appliance clean. Failure to keep the primary air opening(s) of the burner clear may result in sooting and property damage. Inspect these areas of appliance before each use. Have appliance inspected yearly by a qualified service person. Appliance may need more frequent cleaning due to excessive lint form carpeting, bedding material, etc.

First, remove the front glass facia as described in Section 16.0 only in reverse, remove the valve cover (4 screws) and disconnect the gas connection inside appliance. The gas connections to the gas valve can now be released. Undo the four screws retaining the burner brackets to the base and rear of the firebox. The burner may now be removed.

Remove the pilot and main burner pipes and blow through to dislodge any debris. Now remove the in line restrictor and blow through to make sure it is entirely clear.

Unclip the pilot lint gauze and clean with a soft brush. Clean the exterior of the pilot assembly with a soft brush and blow through the flame ports on the pilot head. Check the aeration holes are free from lint or dirt. The pilot assembly can be removed if required by disconnecting the electrode HT lead, gas pipe, thermocouple lead and unscrewing the mounting screws and lifting away. The pilot assembly is a non-serviceable item and should not be taken apart. Aeration holes must be absolutely clear internally for proper operation. **NEVER MODIFY OR BEND THE THERMOCOUPLE TO MAKE THE PILOT STAY LIT.** Modifications are dangerous and can have serious unseen effects on safety. If the pilot will not stay lit there is a problem with dirt, the gas supply to it, or the thermocouple needs replacement.

The gas valve is a non-serviceable item. If this needs replacement, remove the cover plate then the securing screw holding the valve bracket in place, remove all pipe unions, and the complete valve. Replacement must be original manufacturers parts.

Re-assemble in the reverse of removal. Ensure setting pressures are as stated in **Table 1 on Page 3.**

20.0 PILOT ASSEMBLY

WARNING

No adjustments are to be made to the ODS pilot system. Tampering with this system can be extremely hazardous.

Remove the glass facia, glass panel and burner unit (as per servicing section), lint arrestor and pilot assembly by using a screwdriver to remove the retaining screws.

Clean the pilot assembly with a soft brush and blow through. Check the aeration holes are free of any dirt or lint. Clean thoroughly internally, the connection can be removed from the base of the pilot assembly using two spanners to make cleaning easier. Do not damage or try to dismantle the pilot injector. The unit is factory set and the only check necessary is to ensure the spark gap is correct. See **Table 1 on Page 3** for gas setting.

NEVER MODIFY OR BEND THE THERMOCOUPLE TO MAKE THE PILOT STAY LIT. If the pilot will not stay lit there is a problem with dirt, the gas supply, or the thermocouple needs replacement. Modifications are dangerous and can have a serious unseen effect on safety and therefore **MUST** not be done. Replacements must be original manufacturers parts. Re-assemble in the reverse of removal. Ensure setting pressures are as stated in **Table 1 on Page 3.**

21.0 CATALYSTS

! WARNING

Do not block the catalysts or the appliance outlet grill. Blockage may cause high carbon monoxide levels and/or breakage of the glass facia panel.

! WARNING

Do not operate the appliance with the catalyst units removed.

DO NOT BLOCK THESE AREAS

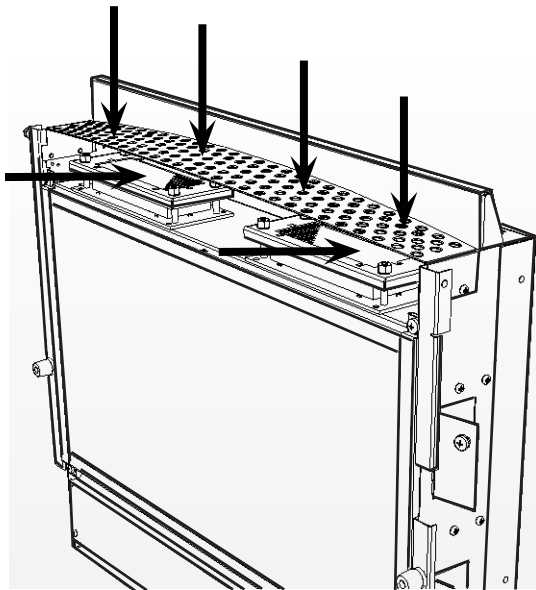

Figure 8 - Catalysts and Outlet Grill

It is recommended that the catalysts are inspected for signs of damage and dirt during routine servicing procedures. The expected life of the catalysts is in excess of 11,000 hours (10 years of normal use). After this time the catalyst should be replaced.

If there are any deposits of dirt or soot on the catalysts they should be cleaned with a soft brush and a vacuum cleaner. If removed for cleaning ensure the seals are in good condition before replacing the catalyst. New seals will usually be required.

The performance of the catalyst may be checked using a combustion gas analyzer as follows.

Important: The temperature of the gases emitted by the catalytic converters is in excess of 700° F. Measuring gas of this temperature may damage some types of gas analyzers. If in doubt consult the equipment manufacturer.

Turn on the fireplace as per the operating instructions, and run at maximum setting for 15 minutes. Position gas sample probe directly over a catalyst via the outlet grill, on top of the appliance. Record the carbon dioxide (CO₂) concentration and then the carbon monoxide (CO) concentration as displayed by the analyzer - also noting the units in which the values are expressed. Most analyzers display carbon dioxide (CO₂) concentrations in percentage (%) terms and carbon monoxide concentration in parts per million (ppm) terms.

In order to calculate the combustion ratio for the appliance (CO/CO₂) it is first necessary to express both gas concentrations in terms of percentage. To convert from parts per million (ppm) to a percentage (%) divide the ppm figure by 10,000. Examples : 35ppm = 0.0035%, 15ppm = 0.0015%, 5ppm = 0.0005%.

Now divide the concentration of carbon monoxide (CO) expressed in percent by the concentration of carbon dioxide (CO₂) to obtain the appliance combustion ratio.

$$\frac{\text{CO} (\%)}{\text{CO}_2 (\%)} = \text{ratio}$$

The combustion ratio of the gasses emitted by the catalytic convertor should not exceed 0.0015.

If replacing, firstly, remove the glass facia as described in Section 16.0. The catalysts are located on the top of the internal firebox and can be removed by unscrewing the retaining nuts securing the clamping plate. Remove the catalysts and seals and discard.

Refit a new catalysts and seals in reverse order, ensure the catalysts and door have good seals.

22.0 TESTING FOR FIREBOX LEAKAGE

Appliances that are several years old or have been extensively dismantled should be checked for soundness. It is important that all the products of combustion pass through the catalytic converters at the top of the firebox before leaving the appliance.

The firebox is heated by lighting for a few minutes to provide a flow through the firebox. The burner is then shut off and a smoke pellet or match introduced at the base of the fire underneath the burner tray. Large quantities of smoke will emerge from the top of the appliance, but none should emerge from the joints or gasket faces, especially around the door. It is important to note that the appliance can never be expected to be 100% smoke tight and small quantities of smoke may be seen in corners of joints and gasket faces etc without affecting safety when the fire is in operation.

23.0 CLEANING

GLASS PANEL -This can be cleaned with a suitable glass cleaner. The following solutions are approved for use to clean glass.

- Non-ammonia based household cleaner
- 50% -50% mix of white vinegar and water
- Gas fireplace/stove glass cleaner

Test on a small area first.

PAINTED AREAS - These can be cleaned using a dry cloth.

FINISHED METAL AREAS - These can either be cleaned using a proprietary metal cleaner or baby oil. Test on a small hidden part before cleaning. Always clean in the direction of the grain.

24.0 LIGHTING INSTRUCTIONS & TURNING OFF APPLIANCE

FOR YOUR SAFETY READ BEFORE LIGHTING

WARNING: IF YOU DO NOT FOLLOW THESE INSTRUCTIONS EXACTLY, A FIRE OR EXPLOSION MAY RESULT CAUSING PROPERTY DAMAGE, PERSONAL INJURY OR LOSS OF LIFE.

- A.** This appliance has a pilot which must be lit with a piezo spark igniter. When lighting the pilot, follow these instructions exactly.
- B.** BEFORE OPERATING smell all around the heater area for gas. Be sure to smell next to the floor because some gas is heavier than air and will settle on the floor.
- WHAT TO DO IF YOU SMELL GAS**
- Do not try to light any appliance.
 - Do not touch any electric switch; do not use any phone in your building.
 - Immediately call your gas supplier from a neighbor's phone. Follow the gas supplier's instructions.
 - If you cannot reach your gas supplier, call the fire department.
- C.** Use only your hand to push in or turn the gas control knob. Never use tools. If the knob will not push in or turn by hand, do not try to repair it, call a qualified service technician. Forced or attempted repair may result in a fire or explosion.
- D.** Do not use this heater if any part has been under water. Immediately call a qualified service technician to inspect the appliance and to replace any part of the control system and any gas control which has been under water.

LIGHTING INSTRUCTIONS

1. Stop! Read the safety information above.
 2. Make sure manual shut-off valve is fully open.
 3. Open the glass facia.
 4. Depress control knob in and turn clockwise to the "OFF" position (Figure 9).
 5. Wait 5 minutes to clear out any gas. Then smell for gas, including near the floor. If you smell gas, STOP! Follow the safety instructions in "What to do if you smell gas" under section 'B' above. If you do not smell gas, go to next step.
 6. The pilot is located on the left side behind the burner (Figure 10).
 7. Depress control knob in and turn counter-clockwise to the "SPARK" position (Figure 9) and hold there for a few seconds.
 8. Continue turning counter-clockwise through the spark click to the PILOT light position, ensuring the pilot has lit. If not, turn the knob fully clockwise, and repeat.
 9. Hold the control knob in for a further 10 seconds to prevent the flame failure detector from shutting off the gas while the probe is warming up.
 10. Release the control knob while turning counter-clockwise to the preferred setting. Close the glass facia.
 11. Wait 30 seconds before readjusting the heater when the control knob has been turned down to a lower setting.
- If the knob does not pop out when released, stop and immediately call your service technician or gas supplier.
 - If the pilot will not stay lit after several tries, depress and turn the gas control knob clockwise to "OFF" and wait 30 seconds. Depress and turn knob counter-clockwise to "SPARK" and ignite the heater again. If your pilot does not relight depress and turn control knob clockwise to "OFF" and call your service technician or gas supplier.
- Note:** If you are running the heater for the first time or after an extended period of non use it will be necessary to press the control knob all the way in for 30 seconds to allow air to bleed out of the gas piping.

TO TURN OFF GAS TO APPLIANCE

1. Open the glass facia.
2. Depress and turn control knob clockwise to the "OFF" position (Figure 9). Close the control access panel.

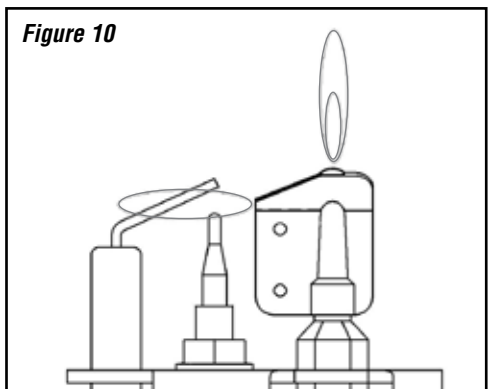

Figure 9

Figure 9: Control knob. This is located behind the glass facia panel of the appliance.

Figure 10: Pilot assembly. This is located behind the burner, on the left-hand side of the appliance.

NOTE: DIAGRAMS & ILLUSTRATIONS ARE NOT TO SCALE



25.0 TROUBLESHOOTING GUIDE

| PROBLEM | CORRECTIVE ACTION |
|--|---|
| <i>Igniter sparks but pilot does not light</i> | <ul style="list-style-type: none"> • No gas to Pilot, check the gas line connections. • Air not fully purged. Purge supply or wait longer. • Spark grounding to metal work, reset gap correctly. • Blocked pilot, clean out internally. |
| <i>Pilot lights but then goes out</i> | <ul style="list-style-type: none"> • Severe restriction in gas supply: clear obstruction. • Faulty thermocouple, replace pilot assembly. • Blocked pilot, clean out. • Blocked lint gauze, clean. • Hold control knob in for longer. • If the pilot will not stay lit there is a problem with dirt, the gas supply, or the thermocouple needs replacement. Modifications are dangerous and can have a serious unseen effect on safety. NEVER MODIFY OR BEND THE THERMOCOUPLE TO MAKE THE PILOT STAY LIT. |
| <i>Igniter electrode at pilot does not spark</i> | <ul style="list-style-type: none"> • HT lead detached,refit. • Check the spark gap (see Section 15.0). • Faulty piezo unit, replace. • Debris shorting out electrode, clean. • Spark shorting to metalwork under tray, realign HT lead. |
| <i>The burner stays on for a period of time, then cuts off</i> | <ul style="list-style-type: none"> • Loose or faulty thermocouple, rectify. • Blocked pilot, clean out. • Dirt or lint in pilot aeration hole or on the lint gauze, clean thoroughly. • If the pilot will not stay lit there is a problem with dirt, the gas supply, or the thermocouple needs replacement. Modifications are dangerous and can have a serious unseen effect on safety. NEVER MODIFY OR BEND THE THERMOCOUPLE TO MAKE THE PILOT STAY LIT. |
| <i>Pilot flame shrinks when fire is on high</i> | <ul style="list-style-type: none"> • Poor gas flow to fire, check pressure with fire on high. • If pressure is low, remove any restriction in pipe-work or valve. • Check all pipe-work are adequately sized. • Check meter pressure is adequate. • If the pilot will not stay lit there is a problem with dirt, the gas supply, or the thermocouple needs replacement. Modifications are dangerous and can have a serious unseen effect on safety. NEVER MODIFY OR BEND THE THERMOCOUPLE TO MAKE THE PILOT STAY LIT. |
| <i>Fireplace smells when first lit or in use</i> | <ul style="list-style-type: none"> • Newness smell from brand new appliance. • Leakage occurring. Carry out leakage test and rectify any problems. • Combustible materials used in incorrect positions. • Unit may require a service to remove dust from catalyts. |

26.0 REPLACEMENT PARTS - RADIUM™

| Item # | Cat. No. | Description |
|--------|----------|---|
| 1 | H6055 | Glass Door Assembly |
| 2 | H7039 | Gas Valve |
| 3 | H6060 | Catalyst |
| 4 | H6061 | Pilot Assembly, Natural Gas |
| 5 | H6999 | Pilot Assembly, Propane Gas |
| 6 | H6056 | Burner Assembly, Natural Gas |
| 7 | H7000 | Burner Assembly, Propane Gas |
| 8 | H6062 | Catalyst Gasket |
| 9 | H6063 | Inlet Pressure Regulator, Natural Gas |
| 10 | H7001 | Inlet Pressure Regulator, Propane Gas |
| 11 | H6066 | Decorative Glass Facia |
| 12 | H6067 | Decorative Rear Frame |
| 13 | H7004 | Gas Strut |
| 14 | H7005 | Knob, Reduced Height |
| 15 | H7006 | Hardware Kit - common fasteners, ceramic clip and rubber bung |

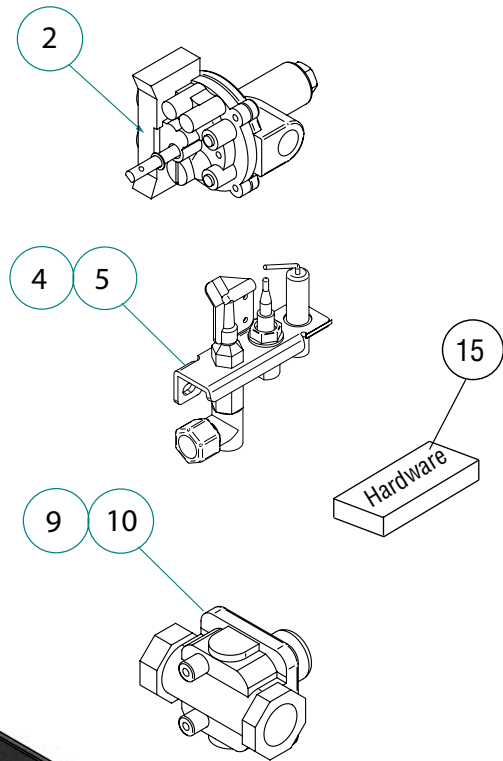

See ordering instructions on **Page 18**

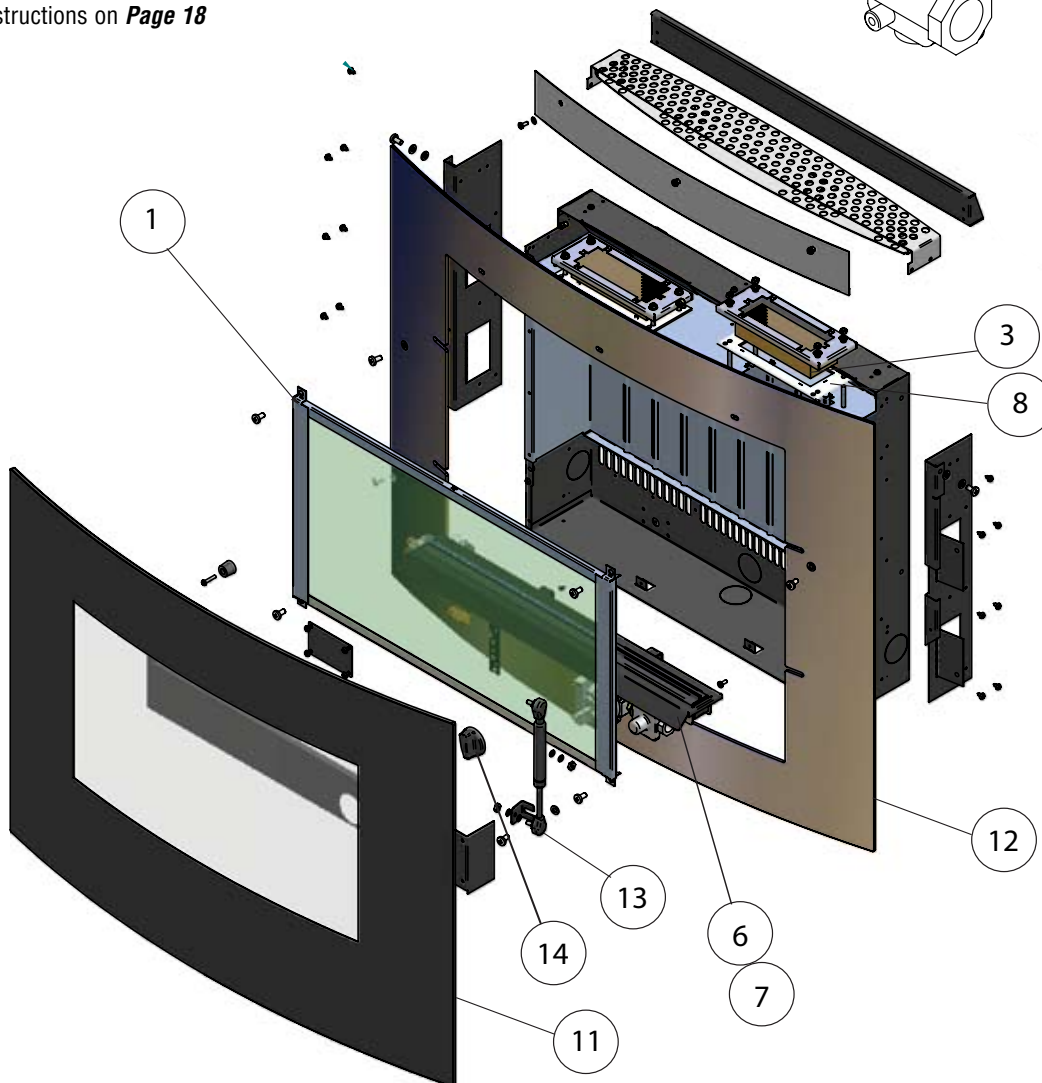

27.0 POSITIONING OF FIELD REMOVABLE PARTS

Removal and refitting of glass door assembly and burner assembly.

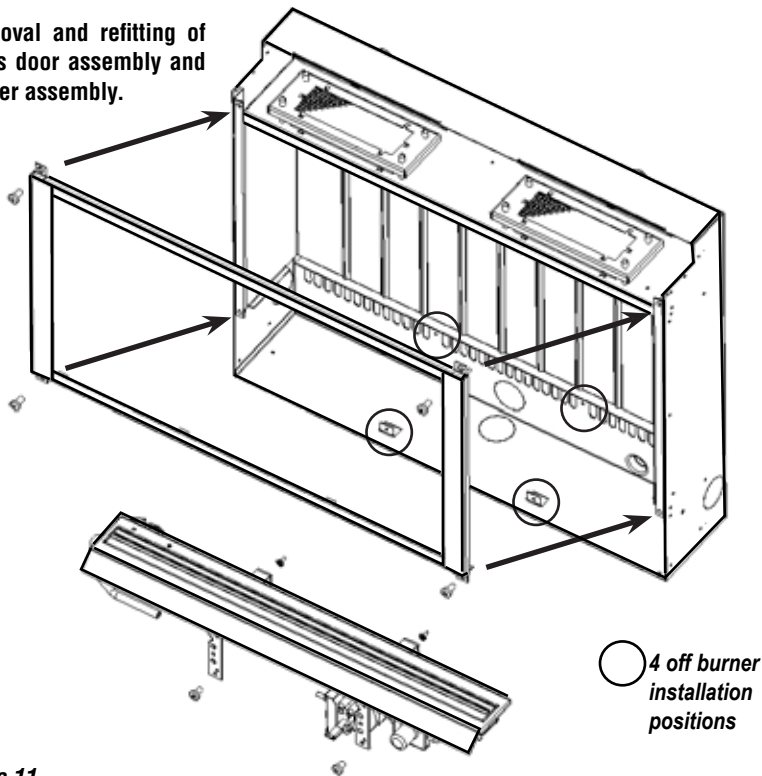

Figure 11

! WARNING

Failure to position the parts in accordance with these diagrams or failure to use only parts specifically approved with this heater may result in property damage or personal injury.

Visual check for correct pilot flame.

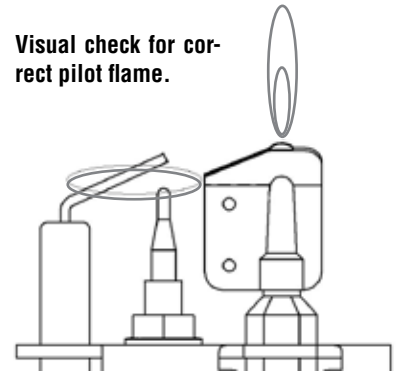

Figure 13

Removal and refitting of the decorative glass fascia (see Section 16.0)

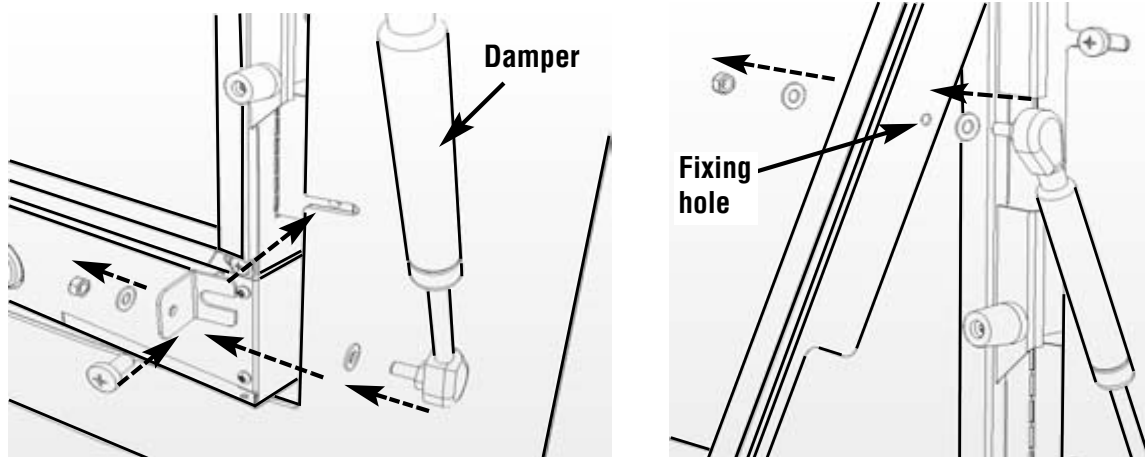
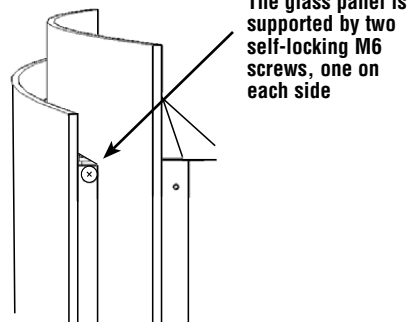

Figure 12

28.0 NOTES

29.0 PRODUCT REFERENCE INFORMATION

WARRANTY

Your gas appliance is covered by a limited warranty. Please read the warranty to be familiar with its coverage.

Retain this manual. File it with your other documents for future reference.

PRODUCT REFERENCE INFORMATION

We recommend that you record the following important information about your appliance. Please contact your Lennox Hearth Products dealer for any questions or concerns. For the number of your nearest Lennox Hearth Products dealer, please call 1-800-9-LENNOX.

REPLACEMENT PARTS

See **Page 15** for a complete replacement parts list. Use only parts supplied from the manufacturer.

Normally, all parts should be ordered through your Lennox distributor or dealer. Parts will be shipped at prevailing prices at time of order.

When ordering repair parts, always give the following information:

1. The model number of the appliance.
2. The serial number of the appliance.
3. The part number.
4. The description of the part.
5. The quantity required.
6. The installation date of the appliance.

If you encounter any problems or have any questions concerning the installation or application of this system, please contact your dealer.

LENNOX HEARTH PRODUCTS
1110 West Taft Avenue
Orange, CA 92865
Visit us at www.Lennox.com

Your Appliance's Model Number _____

Your Fireplace's Serial Number _____

The Date On Which Your Fireplace Was Installed _____

The Type of Gas Your Fireplace Uses _____

Your Dealer's Name _____

Fuel Type Natural Gas Propane Gas

**NATIONAL
FIREPLACE
INSTITUTE**



CERTIFIED
www.nficertified.org

We recommend that our gas hearth products be installed and serviced by professionals who are certified in the U.S. by the National Fireplace Institute® (NFI) as NFI Gas Specialists.

Lennox™ reserves the right to make changes at any time, without notice, in design, materials, specifications, prices and also to discontinue colors, styles and products. Consult your local distributor for fireplace code information.

LENNOXTM

HEARTH PRODUCTS

1110 West Taft Avenue • Orange, CA 92865